

[1].

(J.D.Salinger

'Nine Stories')

1)

2)

3)

4)

J.Salinger "Nine Stories"

«...» [2, . 96]

» [3, . 65].

[4, . 190-192; 5, . 274, 278].

[6, . 13],

()

.1.

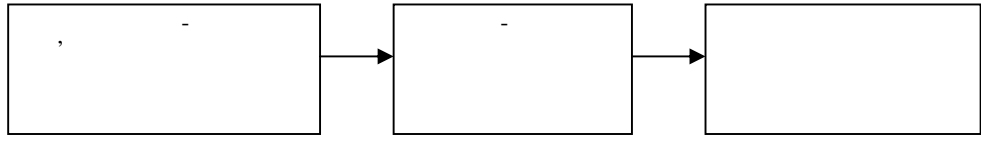

- 1-
- 1.
 - 2.
 - 3.

4.

J. Salinger "Nine Stories"
"A Perfect Day for Bananafish" [7]

», 2003 [8] - 1) (« - »,
2010 [9] - 2) (« - »,
», 1981 [10] - 3).

1 « ↔ (↔ »);
- (2 « ↔ »)
↔ »).
(. . 2).

2 «
↔ », 2 "See more glass".
», «
: Seymour Glass.

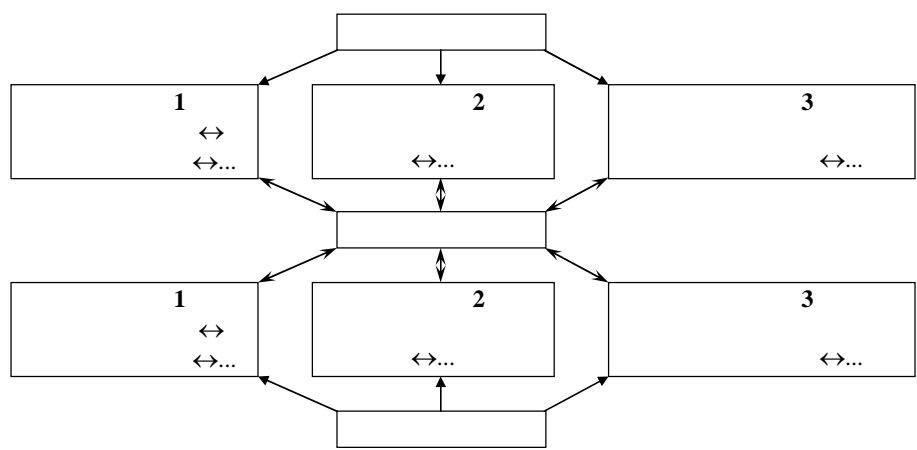

2 - "A Perfect Day for Bananafish" J.D. Salinger

1) - ; 2) () ; 3) () ; 2) (1, 2, 3); 2) (3); 3) 1, 2, 3. 1 « » (3); 3) 2 1, 2, 3. () 3. 2 1, 2, 3.

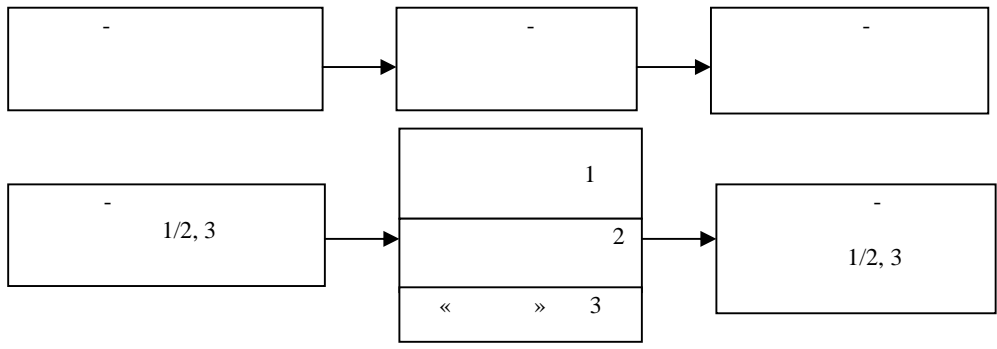

3 - 1, 2, 3 (See more glass... - 1, 2, 3 J.D. Salinger "A Perfect Day for Bananafish")

2 / 2 « 1, 2 » 3, « ».

mink

1, 2 3 « »,

.4.

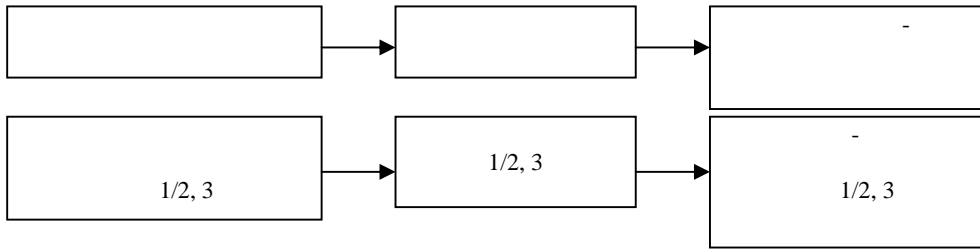

4 -
1/2, 3 (mink -)

2
for Bananafish

1/2, 3
J.D. Salinger "A Perfect Day

pussy); - « » (Mommy), « » (darling), « » (pussycat,
bathing suit). - « » (a fine [bathing suit]), « » (a [blue

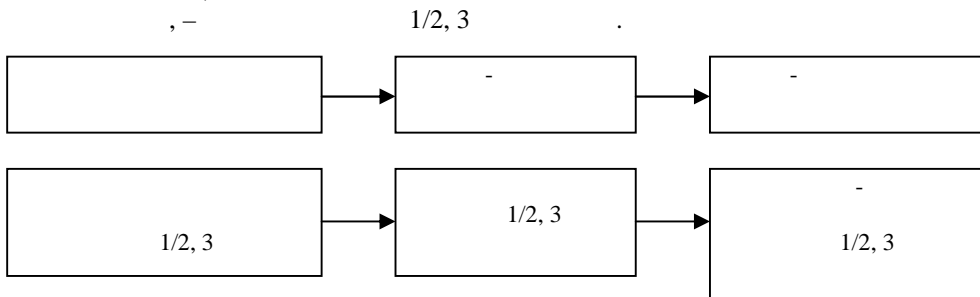

5 -
1/2, 3 (a fine bathing suit -
1/2, 3

J.D. Salinger
"A Perfect Day for Bananafish"

1/2 3 -

“...Mixing memory and desire”.
 « » (“The Wasterland”),
 .6.

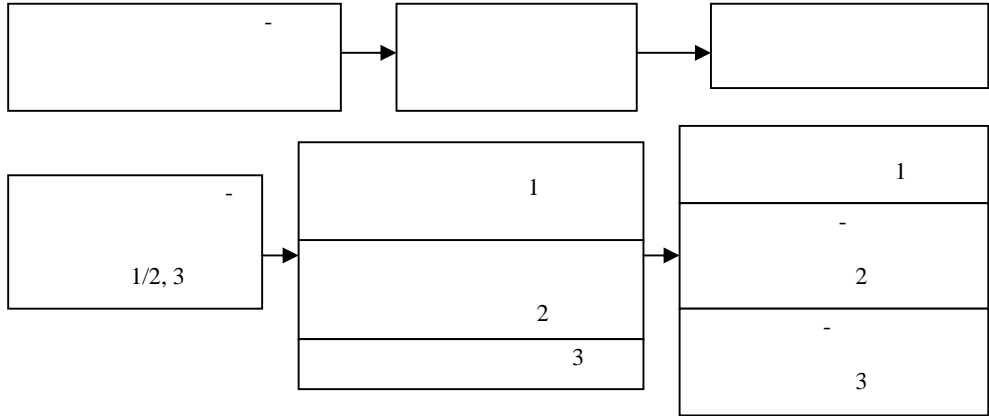

6-
 J.D. Salinger "A Perfect Day for Bananafish"

2 3
 1 2
 3

You have no idea how clear that makes everything.

1: « ...» [9].
 « »

[10]), 3 (« , ...»

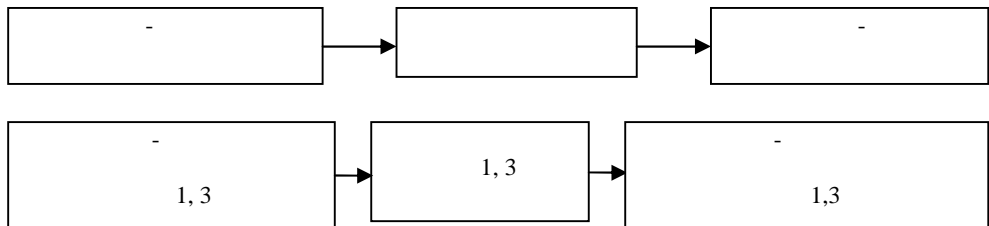

7-
1 3
- 2 J.D. Salinger "A Perfect Day for Bananafish"

1 3

1.

(« », « », « »), « »

« », -

1 -

	1. 2. 3. « » 4. ()	
	1. () 2. -	
	1. 2. 3.	

;

,

;

,

.

-

,

-

1.

1.

2.

3.

4.

5.

1.

**PRAGMATIC TRANSLATION DEFORMATION PECULIARITIES AT THE TEXT MODALITY
CATEGORY LEVEL IN UKRAINIAN AND RUSSIAN TARGET TEXTS**

M.Y. Rebenko,

Analyzed are peculiarities of pragmatic translation deformation phenomenon at the level of fragmentary pragmatically modal fields and their characteristics in target texts. Substantiated is dependence of translation deformation degree on objective text items and their subjective target equivalents correlation level.

Key words: *pragmatic translation deformation, fragmentary pragmatically modal field, functional semantic units of split-level linguistic items, expressive stylistic devices, pragmatic deformation feature.*

1. ... (...) : ... : 10.02.04 / ... - :
... , 2000. – 19 .
2. ... / ... - : ... , 2004. – 280 .
3. ... / ... , 1989. – 144 .
4. ... / ... - :
... , 2010. – 336 .
5. ... // ...
... « ... ».- ... , 2010. – .I - . 274-281.
6. ... / ... - : ... , 2003. – 279 .
7. J.D.Salinger. Nine Stories. Franny and Zooey. Raise High the Roof Beam, Carpenters. Moscow: Progress Publishers, 1982. P. 27-39. –
: <http://jsomers.net/bananafish.doc>.
8. ... / ... // ... -
- 7-8. - « ... », 2004. - . 159-167. - :
<http://kuzmenko.org.ua/uk/salinger/bananafish.doc>.
9. ... / ... - :
<http://stanislavua.livejournal.com/1726.html>.
10. ... - : ... , 2004. – 256 . -
: <http://www.salinger.su/horosh-lovitsa-ribka-bananka.doc>.

12 2011 .