

Studies on Hall Effect and DC Conductivity Measurements of Semiconductor Thin films Prepared by Chemical Bath Deposition (CBD) method

S. Thirumavalavana¹, K. Mani², S. Suresh Sagadevan³

¹ Department of Mechanical Engineering, Sathyabama University, Chennai-600 119, India

² Department of Mechanical Engineering, Panimalar Engineering College, Chennai-602103, India

³ Department of Physics, AMET University, Kanathur, Chennai - 603112, India

(Received 01 October 2015; published online 10 Decembred 2015)

Semiconductors have various useful properties that can be exploited for the realization of a large number of high performance devices in fields such as electronics and optoelectronics. Many novel semiconductors, especially in the form of thin films, are continually being developed. Thin films have drawn the attention of many researchers because of their numerous applications. As the film becomes thinner, the properties acquire greater importance in the miniaturization of elements such as resistors, transistors, capacitors, and solar cells. In the present work, copper selenide (CuSe), cadmium selenide (CdSe), zinc selenide (ZnSe), lead sulphide (PbS), zinc sulphide (ZnS), and cadmium sulphide (CdS) thin films were prepared by chemical bath deposition (CBD) method. The prepared thin films were analyzed by using Hall measurements in Van Der Pauw configuration (ECOPIA HMS-3000) at room temperature. The Hall parameters such as Hall mobility of the material, resistivity, carrier concentration, Hall coefficient and conductivity were determined. The DC electrical conductivity measurements were also carried out for the thin films using the conventional two – probe technique. The activation energies were also calculated from DC conductivity studies.

Keywords: Semiconductor, Thin films, Hall effect, Van Der Pauw method, DC conductivity.

PACS numbers: 72.20. – i, 73.50. – h, 72.20.My

1. INTRODUCTION

The Hall Effect is caused by the action of a magnetic field on the current (electrons) flowing in a solid. Though the Hall Effect was originally discovered in a metal, today it is used mainly for the characterization of semiconductors of thin films. Hall Effect measurements are useful for characterizing virtually every material used in producing semiconductors. The Van Der Pauw method [1] is one of the most utilized measurement methods for the evaluation of electrical properties in semiconductor materials such as resistivity, carrier density, and mobility. The Van Der Pauw method can be used to calculate samples of arbitrary shape, although several basic sample conditions must be satisfied to obtain accurate measurements such as the thickness of the sample must be constant, point contacts placed at the edges of the samples must be used for the measurements, and the sample quality has to be homogeneous. Most semiconductor samples satisfy these conditions, so that this convenient measurement method is widely utilized. Most of the semiconductor thin films are under development to realize high performance novel devices. The Van Der Pauw method is a convenient measurement method for the evaluation of semiconductor thin films. Therefore, newly prepared thin films will be sometimes measured using the Van Der Pauw method to determine film quality as a reference, regardless of their homogeneity. There have been several reports on the influence of inhomogeneity on Van Der Pauw measurements of such unintentional inhomogeneous samples [2-5]. In the present investigation, the Hall Effect and DC conductivity studies were carried out on CuSe, CdSe, ZnSe, PbS, and ZnS thin films.

2. EXPERIMENTAL PROCEDURE

Chemical Bath Deposition is a convenient and low cost technique for producing large area thin film for semiconducting materials, used to deposit on the substrates. The deposition by chemical bath method is frequently carried out in an aqueous solution containing specific chemicals. In the CBD process, the precipitation of compound semiconductor is controlled through the use of suitable complexing agents and the amount of ions. However, CBD technology lacks mainly in aspects such as chemical kinetics and growth mechanisms, which have significant relevance to improving the quality of the materials and processes. A simple chemical bath deposition (CBD) set-up was fabricated in the present work for large area deposition of thin films. This is an inexpensive technique at low deposition temperatures. In addition, the process can be controlled simply by varying pH, time, temperature, and concentration. Thin films of copper selenide (CuSe), cadmium selenide (CdSe), zinc selenide (ZnSe), lead sulphide (PbS), zinc sulphide (ZnS), and cadmium sulphide (CdS) were prepared by CBD method [6-9]. In this work ECOPIA Hall Effect measurement system was used to study the electrical properties such as resistivity, carrier concentration, Hall mobility, Hall coefficient and conductivity of the deposited thin films. The experimental set-up of Hall Effect is shown in Fig. 1.

3. HALL EFFECT MEASUREMENTS

Hall Effect measurements have been valuable tools for analyzing the material characterization. Essentially, the Hall Effect can be observed when the combination of a magnetic field through a sample and a current along the length of the sample creates an electrical

current perpendicular to both the magnetic field and the current, which in turn creates a transverse voltage that is perpendicular to both the magnetic field and the current. The underlying principle is the Lorentz force, that is, the force on a point charge due to electromagnetic fields. Electrical properties such as resistivity, carrier concentration and Hall mobility were estimated from Hall measurements in Van Der Pauw configuration at room temperature.



Fig. 1 – Hall Effect instrument experimental set-up

3.1 Van Der Pauw Configuration

The standard Van Der Pauw technique is employed to determine the Hall parameters. From the Hall parameters, one can determine the type of the charge carriers, carrier concentration, mobility of the charge carriers, and Hall coefficient of the films. The Van Der Pauw method involves applying a current and measuring the voltage using four small contacts on the circumference of a flat, arbitrarily shaped sample of uniform thickness. This method is particularly useful for measuring very small samples because geometric spacing of the contacts is unimportant. Effect due to the size of a sample, which is the approximate probe spacing, is irrelevant. Using this method, the resistivity can be derived from a total of eight measurements that are made around the periphery of the sample with the configurations shown in Fig. 2.

The voltage measurements were taken; two values of resistivity, ρ_A and ρ_B were derived using the relations

$$\rho_A = \frac{\pi}{\ln 2} f_A t_s \frac{(V_1 - V_2 + V_3 - V_4)}{4I} \quad (1)$$

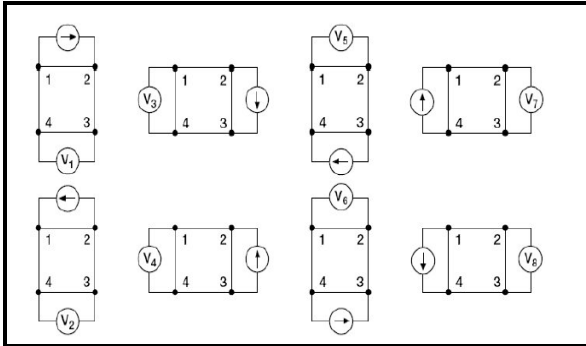

Fig. 2 – Symmetric contacts in Van Der Pauw configuration

$$\rho_B = \frac{\pi}{\ln 2} f_B t_s \frac{(V_5 - V_6 + V_7 - V_8)}{4I} \quad (2)$$

where, ρ_A and ρ_B are resistivities in Ω -cm, t_s is the sample thickness in μm , V_1 - V_8 represents the voltages measured by the voltmeter, I is the current passing through the sample in amperes, f_A and f_B are geometrical factors based on sample symmetry. Once ρ_A and ρ_B are known, the average resistivity (ρ_{AVG}) can be determined as follows:

$$\rho_{AVG} = \frac{\rho_A + \rho_B}{2} \quad (3)$$

The Hall signal was measured between two ends while the current was passing through the other two ends. Hall mobility (μ) is given by the ratio

$$\mu = \Delta R \times \frac{10^8}{BR_{sh}} \quad (4)$$

where ΔR is the change in resistance due to the magnetic field (B) which is applied to measure Hall voltages and R_{sh} is sheet resistance of the material. The resistivity (ρ) is proportional to the reciprocal of the product of the free carrier concentration (n) and the mobility (μ) as is shown in the following relation

$$\rho = \frac{1}{en\mu} \quad (5)$$

The Hall coefficient R_H is given by,

$$R_H = \rho \times \mu \quad (6)$$

The type of carriers can be understood from the sign of the R_H and thus the type of conductivity can be identified. The negative value of R_H corresponds to the flow of electrons (n -type) and positive value corresponds to the flow of holes (p -type) [10].

4. DC CONDUCTIVITY STUDY

The DC conductivity of the thin films was measured using the two-probe technique. The samples were parallel to the cleavage plane to the desired thickness of 1-2 mm. The opposite faces of the thin films were coated with good quality graphite to obtain a good ohmic contact with the electrodes. The resistance of the films was measured using a megohmmeter. The DC conductivity (σ_{dc}) of the film was calculated using the relation,

$$\sigma_{dc} = t / RA, \quad (7)$$

where R is the measured resistance, t is the thickness of the sample, and A is the area of the face in contact with the electrode. The above procedure was used to determine the DC electrical conductivity. The general relation for the temperature variation of conductivity is given by

$$\sigma_{dc} = \sigma_0 \exp[-E / kT], \quad (8)$$

where σ_0 is a constant depending on material, E is the activation energy, T is the absolute temperature, and k

is the Boltzmann's constant. The above equation can be rewritten as

$$\ln \sigma_{dc} = \ln \sigma_0 - E/kT \quad (9)$$

From the plot of $\ln \sigma_{dc}$ versus $1000/T$ we get the slope ($-E/k$) and the intercept ($\ln \sigma_0$). It is customary to plot $\ln \sigma_{dc}$ versus $1000/T$, from the slope of which the activation energy (E) can be calculated.

5. RESULTS AND DISCUSSION

Hall Effect study is a powerful tool for knowing the electronic properties of Semiconductor. Hall measurements are done by Van Der Pauw method at room temperature. The Hall effect can be described by means of the Hall Coefficient RH. The shape of the films is square with point ohmic electrodes being set at the four corners. Thin film samples of area one square cm prepared by (CBD) method were used to carry out the Hall studies. The gold spring probes were placed at the corners of the sample symmetrically as shown in Fig. 2. A constant current of $1\mu\text{A}$ and 1nA was supplied to the films. The films were subjected to uniform magnetic field of 0.57 Tesla. A known current was passed through the electrodes of the films and voltage across the other two electrodes was measured. The polarity was reversed for each measurement and the voltage was measured. The electrical properties of the deposited thin films were studied with the help of Hall measurements in Van Der Pauw configuration (ECOPIA HMS-3000) at room temperature. Hall Effect parameters such as carrier mobility, carrier concentration (n), Hall coefficient (RH), resistivity, and the conductivity were calculated and presented in Table 1.

Table 1 – Hall effect parameters for prepared thin films

Sample	Mobility (μ) (cm^2/Vs)	Resistivity (ρ) (Ωcm)	Carrier concentration (n) ($/\text{cm}^3$)	Conductivity (σ) (Ωcm)	Hall Coefficient (RH) (Cm^3/C)
CuSe	17	6.25×10^{-4}	5.2×10^{20}	1.6×10^{-5}	1.06×10^{-2}
CdSe	88	3.35×10^4	1.65×10^{12}	2.98×10^{-5}	2.95×10^6
ZnSe	14	4.45×10^3	8.53×10^{13}	2.25×10^{-4}	6.23×10^4
PbS	47	4.25×10^2	2.74×10^{12}	2.35×10^{-3}	1.99×10^4
ZnS	63	1.73×10^4	5.36×10^{12}	5.78×10^{-5}	1.08×10^6
CdS	61	4.36×10^4	4.23×10^{12}	2.29×10^{-5}	2.65×10^6

Electrical conductivity depends on the thermal treatment of thin films. The activation energy (E_a) was calculated from the slope of the graph between $\ln \sigma_{dc}$ and $1000/T$ (Figs. 1, 2, 3, 4 and 5). It was found to be 0.040 eV, 0.35 eV, 0.25 eV, 0.40 eV, and 0.60 eV for the thin films CuSe, CdSe, ZnSe, PbS, and ZnS respectively. Evaluation of DC electrical conductivity revealed useful information about materials that could be exploited for various applications. The study of DC electrical conductivity sheds light on the behaviour of charge carriers under a DC field, their mobility and mechanism of conduction.

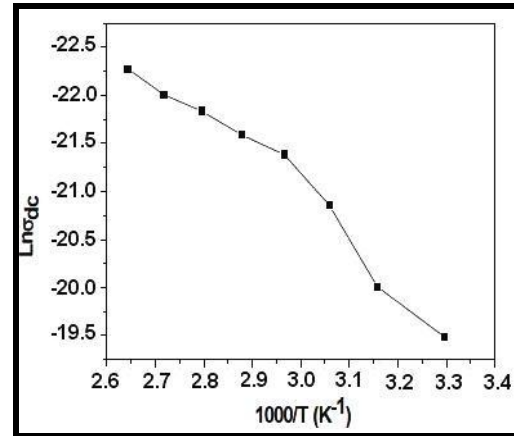

Fig. 1 – Plot of $\ln(\sigma_{dc})$ versus $1000/T$ for CuSe films

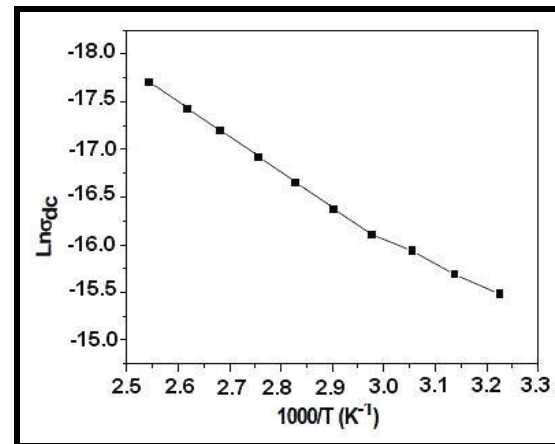

Fig. 2 – Plot of $\ln(\sigma_{dc})$ versus $1000/T$ for CdSe films

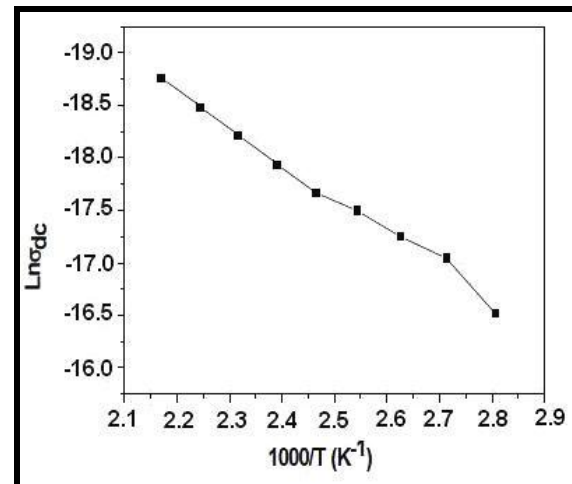

Fig. 3 – Plot of $\ln(\sigma_{dc})$ versus $1000/T$ for ZnSe films

6. CONCLUSION

Hall Effect measurements are used in many phases of the electronics industry, from basic materials research and device development to device manufacturing. Hall Effect parameters such as carrier mobility (μ), carrier concentration (n), Hall coefficient (RH), resistivity (ρ),

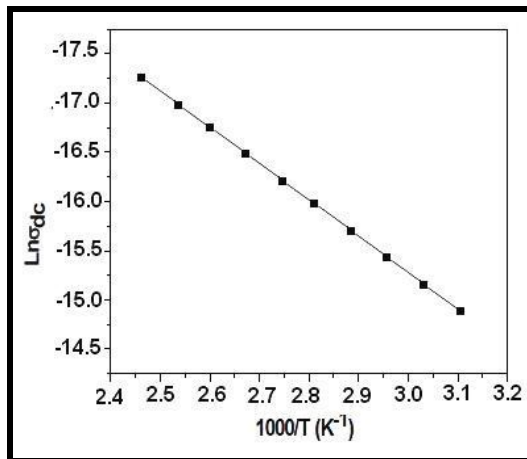

Fig. 4 – Plot of $\ln(\sigma_{dc})$ versus $1000 / T$ for PbS films

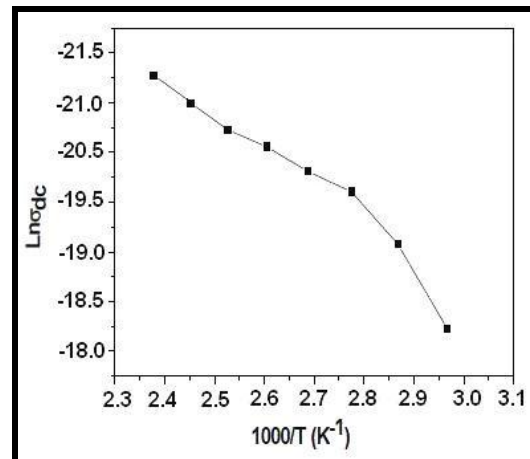

Fig. 5 – Plot of $\ln(\sigma_{dc})$ versus $1000 / T$ for ZnS films

and the conductivity (σ) were calculated on CuSe, CdSe, ZnSe, PbS, ZnS, and CdS thin films. Thus, the electrical properties of the semiconductor thin films were obtained by the Van Der Pauw method. The acti-

vation energy was calculated from DC conductivity studies. It was found to be 0.040 eV, 0.35 eV, 0.25 eV, 0.40 eV, and 0.60 eV for the thin films CuSe, CdSe, ZnSe, PbS, and ZnS respectively.

REFERENCES

1. L.J. Van der Pauw, *Philips Res. Report*, **13**, 1 (1958).
2. D.W. Koon, C.J. Knickerbocker, *Rev. Sci. Instrum.* **67**, 4282 (1996).
3. D.W. Koon, *Rev. Sci. Instrum.* **77**, 094703 (2006).
4. O. Bierwagen, T. Ive, C.G. Van de Walle, J.S. Speck, *Appl. Phys. Lett.* **93**, 242108 (2008).
5. N. Yom-Tov, C. Saguy, A. Bolker, R. Kalish, Y.E. Yaish, *J. Appl. Phys.* **108**, 043711 (2010).
6. S. Thirumavalavan, K. Mani, Suresh Sagadevan, *Chalcogenide Lett.* **12**, 237 (2015).
7. S. Thirumavalavan, K. Mani, S. Sagadevan, *J. Ovonic Res.* **11**, 203 (2015).
8. S. Thirumavalavan, K. Mani, Suresh Sagadevan, *Int. J. Phys. Sci.* **10** No 6, 204 (2015).
9. S. Thirumavalavan, K. Mani, S. Sagadevan, *Sci. Res. Essays* **10**, 378 (2015).
10. K. Schroder Dieter, *Semiconductor Material and Device Characterization, 2nd Edition* (John Wiley & Sons: New York: 1998).