





ANALYSING CUSTOMER LOYALTY, CUSTOMER SATISFACTION AND SERVICE QUALITY AT DLF MALL OF INDIA

Ameet Sao,  <https://orcid.org/0000-0002-0864-9336>
RICS School of Built Environment, Amity University, Noida, India

Amit Kumar,  <https://orcid.org/0000-0003-0824-0546>
Christ University, Ghaziabad, India

Gautam Bapat,  <https://orcid.org/0000-0003-4673-6091>
Dr. Vishwanath Karad MIT World Peace University, India

Mohd. Suhail Khan,  <https://orcid.org/0000-0002-5837-0646>
RICS School of Built Environment, Amity University, Noida, India

Sakshee Singh,  <https://orcid.org/0000-0003-1661-1546>
Graphic Era Hill University, India.

Corresponding author: Dr. Ameet Sao, ameetsao@gmail.com

Type of manuscript: research paper

Abstract: *The intense competition among shopping centre proprietors has led researchers to investigate the factors that influence customer loyalty. To this end, this research was conducted to explore the relationship between customer loyalty, service quality, and customer satisfaction at DLF Mall of India. A survey was conducted using a five-point Likert scale to collect data from customers, which was then analysed using structural equation modelling. The results of the analysis revealed a strong positive relationship between service quality and customer loyalty ($\beta=0.528$, $CR=2.681$, $P<0.05$), customer satisfaction and loyalty ($\beta=0.78$, $CR=1.091$, $P<0.05$), and service quality and customer satisfaction ($\beta=0.65$, $CR=2.014$, $P<0.05$). These findings support the proposed theory and the three hypotheses ($H1$, $H2$, and $H3$) that were formulated. Thus, the present study analysed the factors that contribute to customer loyalty, including service quality and customer satisfaction, in the context of DLF Mall of India and this study will contribute to the existing literature by providing empirical evidence for the significant influence of service quality and customer satisfaction on customer loyalty. Managers of shopping centres can use the insights from this research to enhance the quality of service and customer satisfaction at their establishments, which could ultimately lead to increased customer loyalty. However, the results of this study may not be generalizable to the entire nation, as the research was conducted only in the Delhi-National Capital Region. Further research in other regions of the country could provide a more comprehensive understanding of the factors that influence customer loyalty. This study provides valuable insights into the relationship between service quality, customer satisfaction, and customer loyalty in the context of a shopping centre. The results highlight the importance of providing high-quality service and satisfying customer needs to build long-term relationships with customers. Future research should consider conducting similar studies in other regions to gain a broader perspective of the factors that impact customer loyalty in the retail industry.*

Keywords: customer loyalty, customer satisfaction, service quality.

JEL Classification: D12, D91, L15, L81, M31

Received: 21 December 2022

Accepted: 21 March 2023

Published: 31 March 2023

Funding: There is no funding for this research.

Publisher: Academic Research and Publishing UG

Cite as: Sao, A., Kumar, A., Bapat, G., Khan, M. S., & Singh, S. (2023). Analysing Customer Loyalty, Customer Satisfaction and Service Quality at DLF Mall of India. *Marketing and Management of Innovations*, 1, 146-157 <https://doi.org/10.21272/mmi.2023.1-13>



Copyright: © 2023 by the author. Licensee Academic Research and Publishing UG (i. G.), Germany. This article is an open access article distributed under the terms and conditions of the Creative Commons Attribution (CC BY) license (<https://creativecommons.org/licenses/by/4.0/>).

Introduction. Customer demographics in India have changed significantly during the previous decade. Because of rising consumer disposable income, education, standard of living, and shopping habits, this is the case (Cushman & Wakefield, 2020). The World Bank expects the Indian economy to expand by 8.3 percent in the year 2022. India's economy is on the upswing, thanks to the country's young population and low dependency rate. If India is to continue its rapid economic development, the retail sector must thrive. (IBEF, 2021). It's promising that India has the most retail availability per person. According to the Retail Association of India (RAI), increased government support (in the form of Goods and Services Tax and Foreign Direct Investment) has led to a surge in demand for consumer durables, which in turn has prompted major retailers to invest heavily in shopping malls with the goal of providing Indian consumers with an exceptional retail experience that exceeds their expectations. Due to technological advancements, people's daily routines have been drastically changed. Therefore, while choosing a shopping center, customers are more likely to patronize those that have a wide variety of stores under one roof. In addition to providing for shoppers' basic need, a good shopping center makes their time there pleasant and stress-free. As competition among shopping centers has heated up, every mall has had to come up with unique ways to entice and retain shoppers. Consumers' expectations for the shopping experience have evolved to the point where they cannot be met by online stores alone.

It's no longer enough for consumers to only want to buy things; they also want to be able to spend their money on experiences at popular establishments like movie theatres, nightclubs, fitness centers, spas, and restaurants (Farrag et al., 2010). Owners of retail showrooms on a shopping promenade face intense competition in today's market, making it crucial for them to efficiently manage client satisfaction and loyalty. Rapid growth in consumer income and lifestyle choices has resulted in heightened expectations from consumers about service quality, brand loyalty, and experiences from their favorite retailers (Prashar et al., 2017). Lee and Lin (2005) performed research at a shopping center and found that, when it comes to maintaining a healthy lifestyle, contemporary consumers would rather invest time than money.

The DLF Mall of India is a large retail center located in Noida, Uttar Pradesh, India. There are seven stories and three hundred and thirty stores as well as eighty kiosks, five specialised shopping zones, seventy-five dining and beverage options, and a multiplex with seven screens (PVR Cinemas). The Mall of India, designed and constructed by the British firm Benoy, features six floors of shops selling international and Indian clothing, as well as an atrium with a racetrack, a children's area, entertainment venues, foreign cafés, a food court, restaurants, and a variety of other dining options. It's a popular spot for those looking for food, shopping, and fun.

The paper begins with an introduction that provides background and motivation for the research, as well as the research objectives and questions. The literature review follows, which offers an overview of existing research on customer loyalty, satisfaction, and service quality, as well as the theoretical framework and concepts used in the study. The research methodology section describes the research design and approach, sampling strategy and data collection methods, measures and instruments used in the study, and data analysis techniques. Results and analysis section includes descriptive statistics and analysis of key variables, hypothesis testing and model validation, and discussion of results and implications for the research objectives. The policy implications section presents recommendations for improving service quality and customer satisfaction, as well as the implications for customer loyalty and business performance. Comparison with previous research section compares the findings with previous studies on customer loyalty and satisfaction in the retail industry and discusses similarities and differences. Limitations and future directions section discusses limitations of the study and suggests future research in this area. The conclusion summarizes key findings and contributions to the literature, implications for practitioners and policymakers, and suggestions for future research.

Literature Review. This section of the research involved collecting all relevant data available in peer-reviewed journals and periodicals in order to gain a deeper understanding of the three research variables.

Service quality. Every interaction and exchange a customer have with service provider necessitates the provision of services to satisfy the need (Gronroos, 2000). «The degree of service the organization must deliver to meet or exceed customer expectations» is how Zeithaml et al. (2006), the creators of the SERVQUAL scale, define it. SERVQUAL measures performance along five criteria: assurance, measurables, dependability, empathy, and responsiveness. The concept of service quality has been explored in various areas of marketing, including relationship marketing (Morgan & Hunt, 1994), consumer marketing (Kotler, 2000), services marketing (Gronroos, 2000), and industrial marketing (Hakansson & Snehota, 1995). When creating products based on the servqual dimension, researchers looked at studies done on aspects such visual appeal, aesthetics, physical characteristics, design, the surrounding environment, neatness, hygienic conditions, and tidiness

(Johnston et al.,1990; Brady & Cronin, 2001). To further assess and analyse the connection between customer happiness and customer loyalty, we surveyed experts, analyzed all five aspects, and developed 18 questions as part of SQ. As the organization continues to give services, customers build impressions and gain confidence in the company (Ismail et al.,2006). As a result of technological advancements, shopping malls have also progressed. The original goal was to provide enhanced services and make each purchase an enjoyable one, but the concept has now expanded to include a place for social and emotional satisfaction. If they wish to set themselves apart from the competition, they, too, will need to evolve (Lam et al, 2004). The academic literature has demonstrated a close connection between service quality, customer loyalty, and customer satisfaction (Sureshchandar et al., 2003).

Customer satisfaction. Businesses can't survive without customers; thus, they must be accorded the highest respect as the market's ultimate arbiters. Profitability, market dominance, and public renown depend on consistently exceeding customer expectations. What matters most to retailers is how their customers see the companies that provide them (Wilhelm & Mottner, 2005). Customers are evaluated on their thoughts, feelings, and overall impressions after making a purchase (Minarti & Segoro, 2014). To keep customers happy, it's necessary to cater to their wants and needs (Zeithaml et al, 21996). Discounts, promotions, and other bargains may be offered by stores at shopping malls to attract clients and raise levels of satisfaction (Wirtz, 1993). Food courts and other gathering spaces for shoppers to enjoy one other's company and pass the time are essential features for every modern shopping centre (Wilhelm & Mottner, 2005). The local population should be made aware of the different services offered by store owners using cutting-edge online marketing strategies so that they may be enticed to visit the mall (Millan & Howard, 2007). According to Ahmed et al. (2014), shoppers' pleasure with a mall increases dramatically the instant they make a purchase. In addition, shoppers evaluate their enjoyment and satisfaction after returning home from the mall (Wang, 2008). Customers' propensity to spend more money at a mall is directly related to the degree of excitement and enjoyment they report feeling while shopping there. This in turn promotes mall loyalty and repeat visits.

Customer loyalty. It's how companies maintain contact with their clientele over the long haul. High-retention customers are more likely to keep buying and to behave favourably (Ajzen, 1985). According to Kristensen and Eskildsen (2008), the importance of studied variables generates repeat business (Wong and Sohal, 2003). It was also said that the level of happiness the client feels is directly related to the level of loyalty the customer displays (Wong & Zhou, 2006). Clients are considered loyal if they return for more of the same and recommend the business to others (Lam et al.,2004). According to Oliver (1999), a loyal customer is one who promises to continue using a company's goods or services over time. Dedicated shoppers are optimistic, loyal, and likely to make more purchases in the mall, as shown by the studies conducted by Dimitriades (2006). Customers in the United Arab Emirates prioritise providers that meet their needs in terms of convenience, entertainment, competence, politeness, location, comfort, and elegance. Research by Khare (2011) showed. shoppers are influenced to return to mall based on mall's aesthetics, ambiance, security, product selection, reputation, & word-of-mouth (Farrag et al., 2010).

Several researchers had shown a strong correlation between the trio of our study- service quality, satisfied customers, repeat business (Taylor & Baker 1994; Fornell et al. 1992; Ping, 1993; Rust & Zahorik, 1993; Anderson et al. 1994; Rust et al., 1995). In addition, a select group of scholars has discovered that brand loyalty does not always correspond to consumer satisfaction or quality of service. Considering the evidence presented, we may draw the following conclusions:

H1: Service quality (SQLTY) has positive effect on customer satisfaction (CSTN).

H2: Service quality (SQLTY) has positive effect on customer loyalty (CLTY).

H3: Customer satisfaction has positive effect on consumer loyalty (CLTY).

Methodology and research methods. Elements of study will be examined to determine the nature of the connection between them. To do this, the authors used a questionnaire to compile information from the study's participants. Data collecting and analysis were done using SPSS and SEM. From established literature and previous research, questionnaire was created. The questionnaire is divided into four parts: one to evaluate service quality, another to quantify customer happiness, a third to evaluate customer loyalty, and a fourth to evaluate demographic parameters. The service quality of DLF Mall of India was evaluated using the five dimensions outlined by Parasuraman et al. (1988): tangibles, reliability, assurance, responsiveness, and empathy. The assessment was based on 22 variables that were used to gauge service quality. The information was gathered using 5-point Likert scale, with 5 representing «Highly Satisfied», 4 «Satisfied», 3 «Neutral», and 2 «Dissatisfied» or «Extremely Dissatisfied».

Initially, the questions were tested for readability and comprehension with a pilot study involving data from 25 respondents and data were gathered using convenient sampling strategy. Of the 335 samples collected

from the DLF mall, 290 were retrieved via this inquiry. The reliability of the instrument was confirmed using the Cronbach's Alpha test. Items with values below 0.7 were deemed insignificant and removed from analysis. The same 6 metrics were used to examine customer loyalty, and the same 16 metrics were used to examine consumer contentment. Cronbach's alpha was 79.7%, which means it explained 0.797% of the variance.

The hypothesis was put to the test, and the model's validity verified, using both exploratory, and confirmatory factor analysis. Each component of latent construct was guaranteed to be correlated with one another in these trials (Cao & Mokhtarian, 2005). Until a good model is developed, SEM requires a series of tests (theoretical model, parameter estimate, and final model), when compared to regression analysis, which has limitations when analysing complex variables and detecting linkages between them. Structural equation modelling (SEM) produces improved results with enhanced model fit and estimate accuracy (Gefen, 2000).

Results. Data were collected from consumers at India's DLF mall to assess demographic features. The demographic information of Delhi-NCR customers was included in Table 1.

Table 1. Demographic characteristics

Variables	Characteristics	Frequency	Percent
Age	< 30	85	29.31
	31- 35	75	25.86
	36-40	70	24.14
	> 40	60	20.69
Gender	Male	167	57.59
	Female	123	42.41
Profession	Business	164	56.55
	Service class	126	43.45
Income of family per annum	5-10 lakhs	69	23.79
	10-15 lakhs	79	27.24
	15-20 lakhs	56	19.31
	20-25 lakhs	40	13.79
	>25 lakhs	46	15.86

Sources: developed by the authors.

Confirmatory factory analysis using SPSS & measurement model analysis. The link between observed variables and latent variables or unobserved variables is established through this study (Wong, 2013). Before testing the hypothesis, this model aids in establishing the study's framework. Validity and reliability of the construct are crucial for a successful SEM. To establish internal consistency, reliability and factor-loading is checked. All study variables had KMO values (> 0.7). CFA was performed with SPSS, and Bartlett test of sphericity shows significant result ($P < 0.05$). As per Table 2, latent construct's items were significant and were ranging in between 0.68–0.92. The variables (SQL3, SQL7, SQL10, SQL15, CST5, CST7, CST14) which had factor loading less than 0.65 were eliminated (Hair et. al.,1998). Considering the evaluation, a measurement model was designed.

Table 2. Factor loading-service quality

Items	Sub-Variables	Loading	P-Value	References
Service Quality				
SQLTY1	Knowledge & experience of executives	0.71	***	Parasuraman et al (1988);
SQLTY2	Attention and courteous behaviour of employees.	0.73	***	Hauser and
SQLTY4	Regarding needs and products, the question and concern are addressed with honesty	0.72	***	Clausing, (1988); Phillips et al (1983);
SQLTY5	I believe DLF Mall staff members are competent in providing client service.	0.71	***	DeSouza and Gale(1985)
SQLTY6	Employees communicate in an open and sincere manner.	0.71	***	
SQLTY8	These shopping centres are in a great location.	0.78	***	
SQLTY9	I enjoy shopping because of the physical appearance, atmosphere, lighting, and air conditioner.	0.91	***	
SQLTY11	Proper attention and friendliness of employees	0.87	***	

Continued Table 2

Items	Sub-Variables of Service Quality	Loading	P-Value	References
SQLTY12	To help the client, service providers are well-equipped with information and communication technologies.	0.86	***	Vandamme and
SQLTY13	The staff is always willing to help clients.	0.88	***	Leunis(1993);
SQLTY14	Employees place the customer's needs and concerns first.	0.91	***	Johnston et al (1990); Friman and
SQLTY16	Employees and sales employees show genuine concern and care for consumers.	0.79	***	Edvardsson,
SQLTY17	When clients contact the company online or offline, the sales team and employees respond quickly.	0.72	***	(2003); Reimer and Kuehn,
SQLTY18	The sales team and executives take their responsibility to customers seriously.	0.81	***	2005;
SQLTY19	The crew responds rapidly to client issues.	0.82	***	Sureshchandar et al (2003)
SQLTY20	Executives provide customers with accurate information.	0.76	***	
SQLTY21	The group gives consumers the right kind of service.	0.73	***	
SQLTY22	The efficient satisfaction of individual demand and necessity	0.74	***	
Customer Loyalty				
CLTY1	I'll recommend DLF mall amongst my friends and colleagues.	0.82	***	Heskett et al(1994);
CLTY2	If the necessity arises, it is most likely to make another purchase from DLF again in the future.	0.81	***	Chu,(2009);
CLTY3	I'm willing to try any further goods or services DLF mall provides.	0.74	***	Ganguli and Roy(2011);
CLTY4	I'll probably provide comments on your goods and services so they can be improved.	0.73	***	Caruana(2002);
CLTY5	I'm not interested in hearing sales presentations from your rivals.	0.69	***	Hayes(2008);
CLTY6	I don't aggressively seek out other malls & vendors even though it is required.	0.71	***	Zeithaml et al(2006);
				Duffy(2003)
Customer Satisfaction				
CSTN1	For satisfying client, DLF has streamlined the process to address issues or concern	0.75	***	Kotler et al (1999);
CSTN2	For convenience, I shop in DLF Mall.	0.73	***	Cronin &
CSTN3	DLF met my expectation in terms of information and services.	0.71	***	Taylor(1992)
CSTN4	It offers a cost-effective product.	0.73	***	Gitomer,1998;
CSTN6	The range of goods is adequate for my family's needs.	0.84	***	Liu et al.
CSTN8	The DLF mall of India offers higher-quality goods than its rivals.	0.83	***	(2008); Ahmad (2012), Wong et al. (2012),
CSTN9	The product designs are superior to those of the rivals.	0.87	***	Prashar et al (2017); Kaura (2013);
CSTN10	The property's location is quite accessible.	0.88	***	(2013);
CSTN11	The products and services excite and revitalise customers.	0.88	***	Zeithaml et al, (1996);
CSTN12	The shopping centre helps customers feel better.	0.85	***	Gremler and
CSTN13	Every day brings an unexpected joy and wonder, and I am completely happy with the mall's and the merchants' services.	0.74	***	Gwinner (2000)
CSTN15	Using this mall was a great decision on my part.	0.82	***	
CSTN16	I am quite pleased with the mall's and its stores' services.	0.73	***	

Sources: developed by the authors.

Service quality, customer satisfaction, and customer loyalty -measurement model and model fit. The first stage of SEM testing was to investigate and measure all build measurement models (Holmes-Smith et al.,2006). In the present case, we manually looked into the measurement model to obtain model fit by removing a few more parts that were unnecessary due to insufficient results. 37 items (SQ, CS, and CL) were gathered for this research.

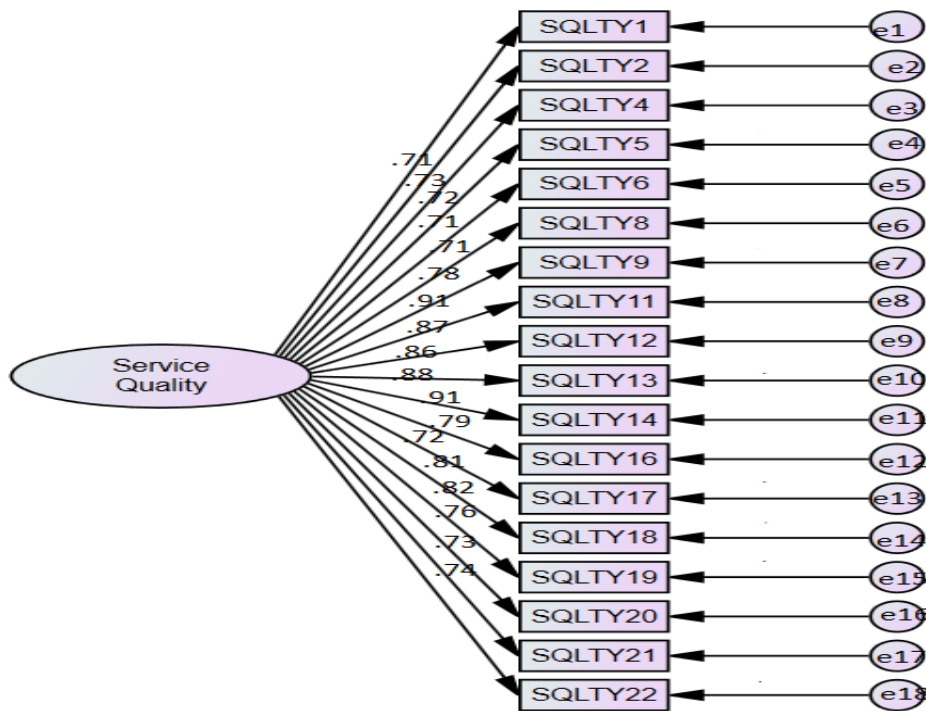

Figure 1. Measurement model - SQ

Sources: Developed by the Authors.

The one-factor model was examined using 18 of the twenty-two items (Service Quality). According to the initial analysis from confirmatory factor analysis, few items is needed to be eliminated from the model, because CMIN/DF=3.23 values were found to be higher than the standard (Hair et al., 1998). The RFI, NFI, TLI, and CFI values were all less than 0.9, while the GFI was about 0.84, the CFI was 0.863, and the RMSEA was 0.078. As a result, by monitoring normalised residual covariance and modification indices, (SQL3, SQL7, SQL10, and SQL15) were deleted. After elimination, the model has CMIN/DF =2.32, CFI = 0.92, GFI = 0.92, and RMSEA =0.031.

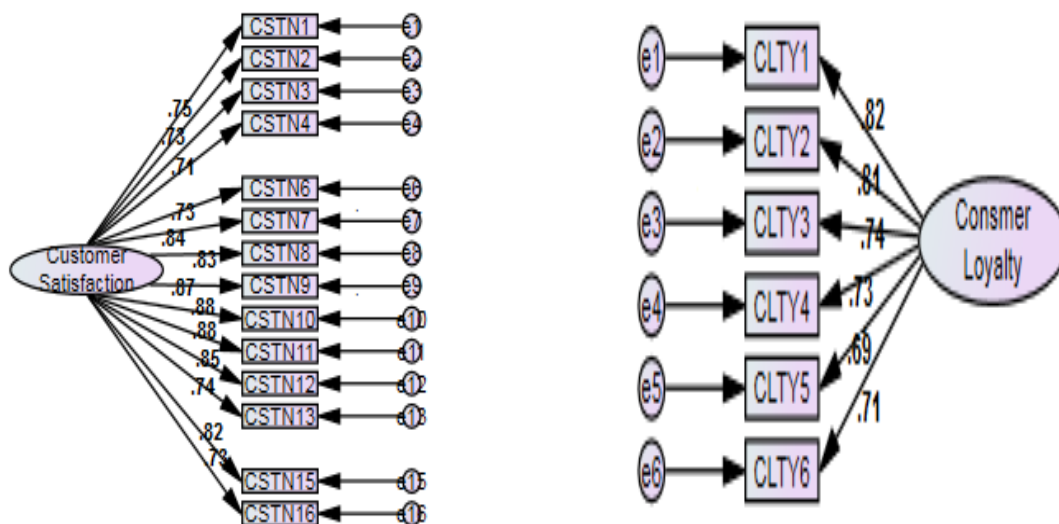

Figure 2. Measurement model

Sources: Developed by the Authors.

Evaluation of the model's appropriateness for fostering client loyalty, six criteria were evaluated. According to Table 5, the chi-square values for CFA are CMIN/DF=2.22, Goodness-of-fit-index (GFI)=0.94, Root mean square error of approximation (RMSEA)=0.067, and (CFI) =0.932. As a result, neither the model nor any of the list items have been modified. Further, 16 items were utilised to analyse customer satisfaction; the initial CFA output suggests that the model needs to be respecified by deleting unnecessary elements. The CMIN/DF, chi-square value is 3.42, the GFI is 0.77, the CFI is 0.841, and the RMSEA is 0.07. So, the CSTNY5, CSTN7, and CSTN14 were deleted for these items by assessing the standardised residual covariance, and 13 items were considered to check the model's fit. The model successfully fits the data, with CFI = 0.89, GFI =.9, CMIN/df = 2.45. Additionally, the construct reliability of the trio was examined, and the results were above the cut-off value of 0.7 at 0.921, 0.922, and 0.911, as indicated in the table. Thus, reliability's internal consistency is demonstrated. Based on average variance retrieved, convergent validity (CV) and divergent validity (DV) of the model measured are assessed (AVE). The scrutiny of the service quality, customer satisfaction and customer loyalty values revealed that they were all higher than the convergent validity threshold of 0.5.

Table 3. Construct Reliability (CR), AVE, Cronbach Alpha

Construct	CR	Cronbach's Alpha	Average Variance Extracted
SQLTY	0.96	0.822	0.62
CSTN	0.95	0.824	0.63
CLTY	0.88	0.833	0.56

Sources: developed by the authors.

Discriminant validity is a construct metric that shouldn't theoretically be related to other constructs (Hair et. al,1998). According to Fornell and Larcker (1981), the AVE > correlation between constructs for discriminant validity. Table 4 makes this evident, and discriminant validity is so established.

Table 4. Discriminant validity

Construct	Service Quality	Customer Satisfaction	Customer Loyalty
SQLTY	0.74		
CSTN	0.64	0.78	
CLTY	0.63	0.56	0.79

Sources: developed by the authors.

The model fit is therefore verified and fulfills the satisfactory fit criteria (Hair et al., 1998). Table5 displays the measurement model's final output.

Table 5. Model fit - SQ, CS, AND CL

Construct	CMIN/DF	CFI	GFI	RMS
SQLTY	2.32	0.92	0.91	0.033
CSTN	2.46	0.91	0.91	0.042
CLTY	2.23	0.93	0.92	0.071

Sources: developed by the authors.

Structural model and testing of hypothesis. The SEM and path diagram are only tested in the second stage once the measurement model has been satisfied (Hair et al.,1998). SEM seeks to identify the connections between latent constructs as well as the latent constructs that influence one another (Byrne, 2013). To determine how latent components may affect the projected model, SEM and a Path diagram are used to analyze it.

Table 6. Results of SEM and hypothesis

Hypothesis	Direct effect of construct	Hypothesis results		CR	P	Hypothesis results
		Estimate	S. E.			
H1	SQLTY---→CSTN	0.143	0.071	2.014	***	Approved
H2	SQLTY---→CLTY	0.177	0.066	2.681	***	Approved
H3	CSTN ---→CLTY	0.143	0.131	1.091	***	Approved

Note: *** is statistical significance (P < 0.05)

Sources: developed by the authors.

Hypothesis test & revised model. As per Table 6, the standard assessment for hypothesis H1 (SQ influences CS positively) is backed at $\beta = 0.74$, $CR = 1.958$, and $P = ***$. Both the hypothesis H2 (SQ has a beneficial impact on CL) and the hypothesis H3 (CS has a positive impact on CL) were tested at $\beta = 0.69$, $CR = 2.626$, and $P = ***$ respectively. The findings of the path analysis and hypothesis are displayed in Table 4. Additionally, the route map shows that the construct was statistically significant at ($P < 0.05$). The suggested structural model and the path diagram are both shown in Figure 3.

Figure 3. Hypothesized structural model

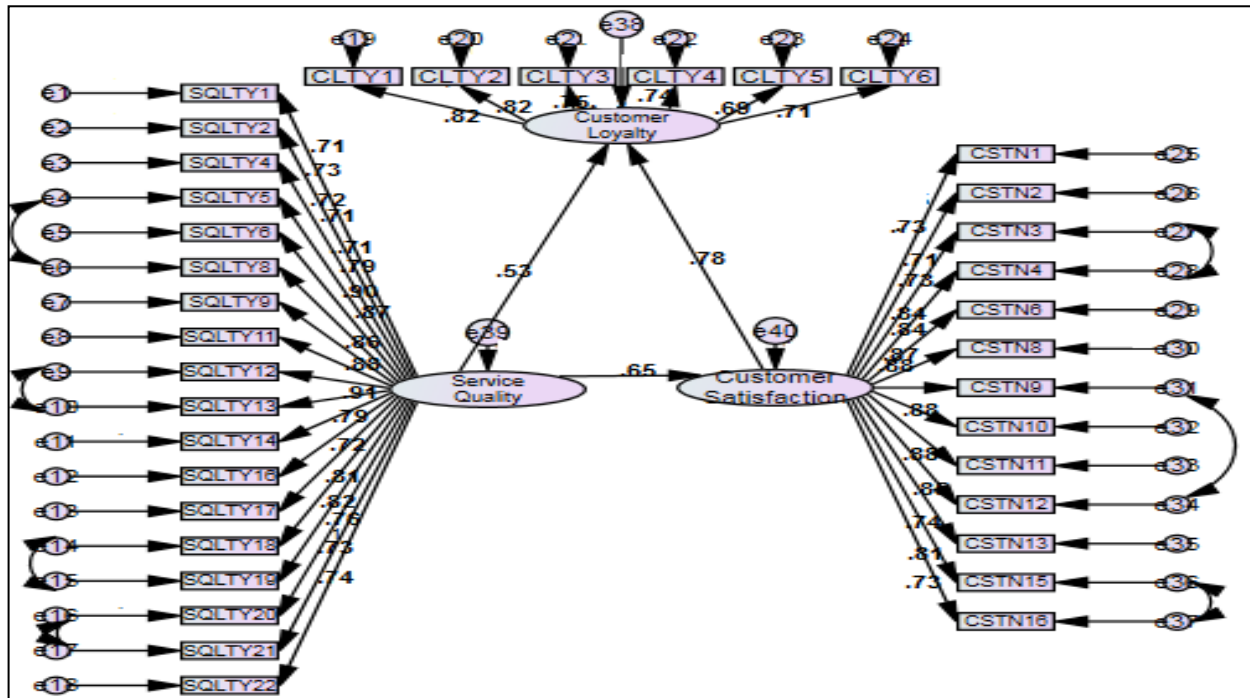

Sources: Developed by the Authors.

Policy implication. The findings of this study have important policy implications for shopping center managers and policymakers. First, the study highlights the importance of service quality in shaping customer loyalty and satisfaction. To enhance customer loyalty and satisfaction, shopping center managers should prioritize the provision of high-quality services and ensure that their employees are trained to deliver excellent customer service. Second, the study suggests that customer satisfaction is a key driver of customer loyalty, indicating that shopping centers should focus on improving customer satisfaction levels by addressing any issues that may negatively impact customer experience. Third, the study shows that customer loyalty has a positive impact on business performance, emphasizing the need for shopping centers to prioritize customer loyalty as a key performance metric. In summary, the study underscores the importance of service quality, customer satisfaction, and customer loyalty in enhancing business performance, and recommends that shopping center managers and policymakers should prioritize these factors in their operations and policies.

Comparison analysis with the previous investigations. Previous studies have investigated the relationship between service quality, customer satisfaction, and customer loyalty in the retail industry. For example, a study by Cronin and Taylor (1992) found that service quality is positively related to customer satisfaction, which in turn is positively related to customer loyalty. Similarly, a study by Sureshchandar et al. (2002) found that service quality is positively related to customer satisfaction and customer loyalty, and that customer satisfaction mediates the relationship between service quality and customer loyalty. These findings are consistent with the results of the current study, which also found a positive relationship between service quality and customer satisfaction, and between customer satisfaction and customer loyalty. However, the current study extends previous research by examining these relationships in the context of a shopping center environment, and by investigating the specific factors that drive customer loyalty and satisfaction in this setting.

Limitations and further direction of investigations. After presenting the results of your study on customer loyalty, customer satisfaction, and service quality at DLF Mall of India, it is important to consider

the limitations of the research and potential directions for future investigation. While this study provides valuable insights into the factors that drive customer loyalty and satisfaction in a shopping center environment, there are several limitations to the study that should be acknowledged, and there is still much to be explored in this area of research.

Limitations:

- One of the limitations of this study is its geographic scope, as the research was conducted only in the Delhi-National Capital Region. Therefore, the results of the study may not be generalizable to other regions in India or to other countries.
- The study used a cross-sectional survey design, which may limit the ability to draw causal inferences about the relationships between service quality, customer satisfaction, and customer loyalty.
- The study focused only on the specific factors that drive customer satisfaction and loyalty in the context of a shopping center environment, and did not investigate other potential factors that may impact customer behavior, such as pricing or product selection.

Further directions for investigation:

- This study focused on a single shopping center, and future research could investigate whether the findings are consistent across multiple shopping centers or retail settings to examine the generalizability of the findings with respect to different malls.
- Longitudinal studies or experimental designs could be used to establish causal relationships between service quality, customer satisfaction, and customer loyalty.
- Future research could investigate the role of emerging technologies, such as mobile apps or social media, in shaping customer loyalty and satisfaction in the shopping center environment.

Conclusions. In the present study, we looked at how different dimensions of service quality influenced customers' perceptions of and commitment to a company. We employed a well-thought-out survey to probe the synergy between the three in serving the ends. Satisfaction of customers and the quality of services provided are two key factors in creating loyal customers, according to studies. The findings demonstrate a positive relationship between satisfied customers and high-quality service. Given these findings, we find H1 to be reasonable and consistent with them (Johnson et al., 2001). The research also found that high-quality service had a beneficial effect on consumer loyalty, lending credence to hypothesis H2 (Johnson et al., 2001). Consistent with the results of Hypothesis Two, the investigation of the effect of Hypothesis 3 on Customer Loyalty found that Customer Satisfaction positively Affects Customer Loyalty (Anderson and Sullivan, 1993). Further, client happiness is directly proportional to the quality of services provided to them, and loyalty is a direct result of satisfied customers. The results will help academics and mall administrators better understand the significance of service quality, customer happiness, and consumer loyalty. This study shows that to keep customers and make money in the face of stiff competition, mall managers need to pay attention to and strategy around these factors.

Author Contributions: conceptualization, A. S.; methodology, A. K. and G. B.; software, S. K. and S. S.; validation, S. S.; formal analysis, A. K. and G. B.; investigation, S. K., S. S. and A. K.; resources, A. S.; data curation, G. B.; writing-original draft preparation, S. K.; writing-review and editing, S. S., A. S. and G. B.; visualization, S. K.; supervision, S. S.; project administration, A. S.; funding acquisition, A. K.

Conflicts of Interest: Authors declare no conflict of interest.

Data Availability Statement: Not applicable.

Informed Consent Statement: Not applicable.

References

- Ahmed, Z., Rizwan, M., Ahmad, M., & Haq, M. (2014). Effect of brand trust and customer satisfaction on brand loyalty in Bahawalpur. *Journal of sociological research*, 5(1), 306-326. [\[Google Scholar\]](#)
- Ajzen, I. (1985). *From intentions to actions: A theory of planned behavior*. In J. Kuhl & J. Beckmann (Eds.), *Action control: From cognition to behavior* 11-39. Springer. [\[Google Scholar\]](#)
- Anderson, E. W. (1994). Cross-category variation in customer satisfaction and retention. *Marketing letters*, 5, 19-30. [\[Google Scholar\]](#) [\[CrossRef\]](#)
- Anderson, E. W. (1996). Customer satisfaction and price tolerance. *Marketing letters*, 7, 265-274. [\[Google Scholar\]](#) [\[CrossRef\]](#)

- Anderson, E. W., & Sullivan, M. W. (1993). The antecedents and consequences of customer satisfaction for firms. *Marketing science*, 12(2), 125-143. [[Google Scholar](#)] [[CrossRef](#)]
- Bitner, M. J. (1992). Servicescapes: The impact of physical surroundings on customers and employees. *Journal of marketing*, 56(2), 57-71. [[Google Scholar](#)] [[CrossRef](#)]
- Brady, M. K., & Cronin Jr, J. J. (2001). Some new thoughts on conceptualizing perceived service quality: a hierarchical approach. *Journal of marketing*, 65(3), 34-49. [[Google Scholar](#)] [[CrossRef](#)]
- Cao, Y., & Zhao, H. (2004). Evaluations of e-tailers' delivery fulfillment: implications of firm characteristics and buyer heterogeneity. *Journal of Service Research*, 6(4), 347-360. [[Google Scholar](#)] [[CrossRef](#)]
- Caruana, A. (2002). Service loyalty: The effects of service quality and the mediating role of customer satisfaction. *European journal of marketing*, 36(7/8), 811-828. [[Google Scholar](#)] [[CrossRef](#)]
- Chang, Y. H., & Yeh, C. H. (2002). A survey analysis of service quality for domestic airlines. *European journal of operational research*, 139(1), 166-177. [[Google Scholar](#)] [[CrossRef](#)]
- Chu, K. M., & Shiu, C. (2009). The construction model of customer trust, perceived value and customer loyalty. *The Journal of American Academy of Business, Cambridge*, 14(2), 98-103. [[Google Scholar](#)]
- Cronin Jr, J. J., & Taylor, S. A. (1992). Measuring service quality: a reexamination and extension. *Journal of marketing*, 56(3), 55-68. [[Google Scholar](#)] [[CrossRef](#)]
- Cushman & Wakefield. (2020). Demographic Shifts: The World in 2030. Retrieved from [[Link](#)].
- Dabholkar, P. A., Thorpe, D. I., & Rentz, J. O. (1996). A measure of service quality for retail stores: scale development and validation. *Journal of the Academy of marketing Science*, 24, 3-16. [[Google Scholar](#)] [[CrossRef](#)]
- Dimitriades, Z. S. (2006). Customer satisfaction, loyalty and commitment in service organizations: Some evidence from Greece. *Management Research News*, 29(12), 782-800. [[Google Scholar](#)] [[CrossRef](#)]
- Duffy, D. L. (2003). Internal and external factors which affect customer loyalty. *Journal of consumer marketing*, 20(5), 480-485. [[Google Scholar](#)] [[CrossRef](#)]
- Farrag, D. A., El Sayed, I. M., & Belk, R. W. (2010). Mall shopping motives and activities: a multimethod approach. *Journal of International Consumer Marketing*, 22(2), 95-115. [[Google Scholar](#)] [[CrossRef](#)]
- Fornell, C. (1992). A national customer satisfaction barometer: The Swedish experience. *Journal of marketing*, 56(1), 6-21. [[Google Scholar](#)] [[CrossRef](#)]
- Fornell, C., & Larcker, D. F. (1981). Evaluating structural equation models with unobservable variables and measurement error. *Journal of marketing research*, 18(1), 39-50. [[Google Scholar](#)] [[CrossRef](#)]
- Friman, M., & Edvardsson, B. (2003). A content analysis of complaints and compliments. *Managing Service Quality: An International Journal*. [[Google Scholar](#)] [[CrossRef](#)]
- Ganguli, S., & Roy, S. K. (2011). Generic technology-based service quality dimensions in banking: Impact on customer satisfaction and loyalty. *International journal of bank marketing*, 29(2), 168-189. [[Google Scholar](#)] [[CrossRef](#)]
- Gefen, D., Straub, D., & Boudreau, M. C. (2000). Structural equation modeling and regression: Guidelines for research practice. *Communications of the association for information systems*, 4(1), 7. [[Google Scholar](#)] [[CrossRef](#)]
- Gitomer, J. (1998). *Customer satisfaction is worthless, customer loyalty is priceless* (p. 288). Marietta, GA: Bard Press. [[Google Scholar](#)]
- Gremler, D. D., & Gwinner, K. P. (2000). Customer-employee rapport in service relationships. *Journal of service research*, 3(1), 82-104. [[Google Scholar](#)] [[CrossRef](#)]
- Gronroos, C. (1984). A service quality model and its marketing implications. *European Journal of marketing*, 18(4), 36-44. [[Google Scholar](#)] [[CrossRef](#)]
- Gronroos, C. (2000). Service management and marketing/C. *Gronroos–West Sussex*, 239. [[Google Scholar](#)]
- Hair, J. F., Anderson, R. E., Tatham, R. L., & Black, W. C. (1998). *Multivariate data analysis*. Englewood cliff. *New jersey, USA*, 5(3), 207-2019. [[Google Scholar](#)]
- Hakansson, H., & Snehota, I. (1995). *Developing Relationships in Business Networks*. [[Google Scholar](#)]
- Hauser, J., & Clausing, D. (1988). The House of Quality. *Harvard Business Review*, 66, 63-73. [[Google Scholar](#)]
- Hayes, B. E. (2008). The true test of loyalty. *Quality progress*, 41(6), 20. [[Google Scholar](#)]
- Heskett, J. L., Jones, T. O., Loveman, G. W., Sasser, W. E., & Schlesinger, L. A. (1994). Putting the service-profit chain to work. *Harvard business review*, 72(2), 164-174. [[Google Scholar](#)]

Holmes-Smith, P., Coote, L., & Cunningham, E. (2006). Structural equation modeling: From the fundamentals to advanced topics. *Melbourne: Sreams*.

India Brand Equity Foundation (IBEF). (2021). Retail Industry in India. Retrieved from [\[Link\]](#)

Ismail, I., Haron, H., Nasir Ibrahim, D., & Mohd Isa, S. (2006). Service quality, client satisfaction and loyalty towards audit firms: Perceptions of Malaysian public listed companies. *Managerial auditing journal*, 21(7), 738-756. [\[Google Scholar\]](#) [\[CrossRef\]](#)

Johnson, M. D., Herrmann, A., & Huber, F. (2001). The evolution of loyalty intentions. *Journal of Marketing*, 65(3), 33-44. [\[Google Scholar\]](#) [\[CrossRef\]](#)

Johnston, R., & Fern, N. (1990). Service quality: A strategic issue in management. In *Advances in Services Marketing and Management*, 1(1), 31-51.

Kaura, V. (2013). Antecedents of customer satisfaction: a study of Indian public and private sector banks. *International Journal of Bank Marketing*. [\[Google Scholar\]](#) [\[CrossRef\]](#)

Khare, A. (2011). Mall shopping behaviour of Indian small town consumers. *Journal of retailing and consumer services*, 18(1), 110-118. [\[Google Scholar\]](#) [\[CrossRef\]](#)

Kotler, P. (2000). *Marketing Management, The Millenium Ed* Prentice Hall Inc. *New Jersey. USA*.

Kotler, P., & Keller, K. (2011). *Marketing management (14 ed.)*. Prentice Hall.

Kotler, P., Bowen, J. T., & Makens, J. C. (1999). *Marketing for Hospitality and Tourism* (5th ed.). Pearson Education India.

Kristensen, K., & Eskildsen, J. (2008). Integrating SERVQUAL with national customer satisfaction indices. In *Proceedings of the 13th International Conference on ISO9000 & TQM, Kuala Lumpur, Malaysia, May* (pp. 26-28). [\[Google Scholar\]](#)

Lam, S. Y., Shankar, V., Erramilli, M. K., & Murthy, B. (2004). Customer value, satisfaction, loyalty, and switching costs: an illustration from a business-to-business service context. *Journal of the academy of marketing science*, 32(3), 293-311. [\[Google Scholar\]](#) [\[CrossRef\]](#)

Lee, G. G., & Lin, H. F. (2005). Customer perceptions of e-service quality in online shopping. *International journal of retail & distribution management*. [\[Google Scholar\]](#) [\[CrossRef\]](#)

Millan, E. S., & Howard, E. (2007). Shopping for pleasure? Shopping experiences of Hungarian consumers. *International Journal of Retail & Distribution Management*, 35(6), 474-487. [\[Google Scholar\]](#) [\[CrossRef\]](#)

Minarti, S. N., & Segoro, W. (2014). The influence of customer satisfaction, switching cost and trusts in a brand on customer loyalty–The survey on student as IM3 users in Depok, Indonesia. *Procedia-Social and Behavioral Sciences*, 143, 1015-1019. [\[Google Scholar\]](#) [\[CrossRef\]](#)

Morgan, R. M., & Hunt, S. D. (1994). The commitment-trust theory of relationship marketing. *Journal of marketing*, 58(3), 20-38. [\[Google Scholar\]](#) [\[CrossRef\]](#)

Oliver, R. L. (1999). Whence consumer loyalty?. *Journal of marketing*, 63(4_suppl1), 33-44. [\[Google Scholar\]](#) [\[CrossRef\]](#)

Parasuraman, A., Zeithaml, V. A., & Berry, L. (1988). SERVQUAL: A multiple-item scale for measuring consumer perceptions of service quality. *1988*, 64(1), 12-40. [\[Google Scholar\]](#)

Phillips, L. W., Chang, D. R., & Buzzell, R. D. (1983). Product quality, cost position and business performance: a test of some key hypotheses. *Journal of marketing*, 47(2), 26-43. [\[Google Scholar\]](#) [\[CrossRef\]](#)

Ping Jr, R. A. (1993). The effects of satisfaction and structural constraints on retailer exiting, voice, loyalty, opportunism, and neglect. *Journal of retailing*, 69(3), 320-352. [\[Google Scholar\]](#) [\[CrossRef\]](#)

Prashar, S., Singh, H., Parsad, C., & Vijay, T. S. (2017). Predicting Indian shoppers' malls loyalty behaviour. *Vikalpa*, 42(4), 234-250. [\[Google Scholar\]](#)

Rust, R. T., & Zahorik, A. J. (1993). Customer satisfaction, customer retention, and market share. *Journal of retailing*, 69(2), 193-215. [\[Google Scholar\]](#) [\[CrossRef\]](#)

Rust, R. T., Zahorik, A. J., & Keiningham, T. L. (1995). Return on quality (ROQ): Making service quality financially accountable. *Journal of marketing*, 59(2), 58-70. [\[Google Scholar\]](#) [\[CrossRef\]](#)

Rust, R. T., Zahorik, A. J., & Keiningham, T. L. (1996). *Service marketing. (No Title)*. [\[Google Scholar\]](#)

Sureshchandar, G. S., Rajendran, C., & Anantharaman, R. N. (2003). Customer perceptions of service quality in the banking sector of a developing economy: a critical analysis. *International journal of bank marketing*, 21(5), 233-242. [\[Google Scholar\]](#) [\[CrossRef\]](#)

Tax, S. S., & Brown, S. W. (1998). Recovering and learning from service failure. *MIT Sloan Management Review*. [\[Google Scholar\]](#)

Taylor, S. A., & Baker, T. L. (1994). An assessment of the relationship between service quality and customer satisfaction in the formation of consumers' purchase intentions. *Journal of retailing*, 70(2), 163-178. [[Google Scholar](#)] [[CrossRef](#)]

Vandamme, R., & Leunis, J. (1993). Development of a multiple-item scale for measuring hospital service quality. *International Journal of Service Industry Management*, 4(3), 0-0. [[Google Scholar](#)] [[CrossRef](#)]

Wang, Y. S. (2008). Assessing e-commerce systems success: a respecification and validation of the DeLone and McLean model of IS success. *Information systems journal*, 18(5), 529-557. [[Google Scholar](#)] [[CrossRef](#)]

Wilhelm, W. B., & Mottner, S. (2005). Teens and shopping mall preferences: A conjoint analysis approach to understanding the generational shift toward an experience economy. *Journal of Shopping Center Research*, 12(1), 23-52. [[Google Scholar](#)]

Wirtz, J. (1993). A critical review of models in consumer satisfaction. *Asian Journal of Marketing*, 2(1), 7-22. [[Google Scholar](#)]

Wong, A., & Sohal, A. (2003). A critical incident approach to the examination of customer relationship management in a retail chain: an exploratory study. *Qualitative Market Research: An International Journal*, 6(4), 248-262. [[Google Scholar](#)] [[CrossRef](#)]

Wong, A., & Zhou, L. (2006). Determinants and outcomes of relationship quality: a conceptual model and empirical investigation. *Journal of International Consumer Marketing*, 18(3), 81-105. [[Google Scholar](#)] [[CrossRef](#)]

Wong, K. K. K. (2013). Partial least squares structural equation modeling (PLS-SEM) techniques using SmartPLS. *Marketing Bulletin*, 24(1), 1-32. [[Google Scholar](#)]

Zeithaml, V. A., Berry, L. L., & Parasuraman, A. (1996). The behavioral consequences of service quality. *Journal of marketing*, 60(2), 31-46. [[Google Scholar](#)] [[CrossRef](#)]

Zeithaml, V. A., Bitner, M. J., & Gremler, D. D. (2006). *Services marketing: Integrating customer focus across the firm*. McGraw-Hill/Irwin. [[Google Scholar](#)]

Амет Сао, Університет Аміті, Індія

Аміт Кумар, Університет Христа, Індія

Гаутам Бапат, Університет світу Массачусетського технологічного інституту, Індія

Мохд. Сухейл Хан, Університет Аміті, Індія

Сакші Сінгх, Університет графічної ери Хілл, India

Дослідження лояльності, задоволеності клієнтів та якості наданих послуг: кейс DLF MALL в Індії

Ця стаття узагальнює аргументи та контраргументи в межах наукової дискусії з питання підвищення лояльності споживачів. Високий рівень конкуренції торгових центрів обумовлює необхідність виявлення факторів, які впливають на лояльність споживачів. Основною метою проведеного дослідження є визначення зв'язку між лояльністю, обслуговуванням високої якості та задоволенням клієнтів. Інформаційна база дослідження була сформована на основі проведеного опитування клієнтів DLF Mall в Індії за п'ятибальною шкалою Лайкерта. Методичним інструментарієм проведеного дослідження стали методи структурного моделювання. В статті представлено результати емпіричного аналізу, який засвідчив сильний позитивний зв'язок між якістю обслуговування та лояльністю клієнтів ($\beta=0,528$, $CR=2,681$, $P<0,05$), задоволеністю та лояльністю клієнтів ($\beta=0,78$, $CR=1,091$, $P<0,05$) та обслуговуванням, якістю і задоволеністю клієнтів ($\beta=0,65$, $CR=2,014$, $P<0,05$). Отримані результати дозволили визначити фактори, які сприяють підвищенню рівня лояльності клієнтів, включаючи якість обслуговування та задоволеність клієнтів. Наукова новизна одержаних результатів полягає у створенні теоретико-методологічного та методичного підґрунтя забезпечення лояльності споживачів. Результати дослідження підкреслюють важливість надання високоякісних послуг і задоволення потреб клієнтів для побудови довгострокових відносин зі споживачами. Результати проведеного дослідження можуть бути корисними для менеджерів торгових центрів при формуванні стратегії підвищення якості обслуговування та задоволеності клієнтів. Окреслено подальші напрями дослідження, які в першу чергу стосуються розширення вибірки дослідження, що сприятиме розширенню факторів, які впливають на лояльність клієнтів.

Ключові слова: лояльність клієнтів, задоволеність клієнтів, якість обслуговування.