



DETERMINANTS OF TECHNOPRENEURIAL INTENTION AMONG UNIVERSITY STUDENTS: INDIVIDUAL ENTREPRENEURIAL ORIENTATION (IEO) AS MEDIATOR

Wei-Loon Koe,  ORCID: <https://orcid.org/0000-0003-3977-1884>

Ph.D., University Teknologi MARA, Malaysia

Mohd Rusydi Abdul Rahim,  ORCID: <https://orcid.org/0009-0005-4341-5729>

University Teknologi MARA, Malaysia

Mohd Halim Mahphoth,  ORCID: <https://orcid.org/0000-0002-0935-3609>

Ph.D., University Teknologi MARA, Malaysia

Corresponding author: Wei-Loon Koe, koewei516@uitm.edu.my

Type of manuscript: research paper

Abstract: *Technology-based entrepreneurship or technopreneur-ship is crucial in driving business innovations in a country, especially in the Industrial Revolution 4.0 era. To date, the Malaysian government has put forth various efforts and implemented many strategies to develop youth technopreneurs. However, the establishment of new technological businesses still needed to be higher. In addition, reluctance to embark on entrepreneurship among university students remained a main issue and challenge. Therefore, the ultimate purpose of this study was to investigate the determinants of technopreneurial intention among university students. The mediating role of individual entrepreneurial orientation (IEO) was also tested. This study employed the Theory of Planned Behavior (TPB) and the concept of IEO as the underpinning theories in developing the model of research and hypotheses. The research method adopted was quantitative because all variables were quantifiable. In particular, it utilised a survey questionnaire. The object of the research was individual university students chosen from a public university in Malaysia. A total of 5030 students was identified as the population of the study. Based on the proportionate stratified random sampling, 358 students were selected as a sample and surveyed. The collected data were further analysed using covariance-based structural equation modelling (CB-SEM). The findings empirically confirmed that contextual elements significantly and positively influenced technopreneurs' intentions. However, computer and Internet self-efficacy were not significant in influencing technopreneurial intention. IEO significantly mediated the relationship between contextual elements and technopreneurs' intention regarding mediation testing. This research proved that aspects of contextual elements such as access to capital, access to information, and social networks were important in encouraging and developing technopreneurs. Furthermore, it confirmed a model for understanding and bolstering technopreneurial intention. It helped the government find significant external factors influencing students' technopreneurial intention. It also sheds light on establishing effective ways of developing technopreneur-ship among youths early.*

Keywords: entrepreneurship, motivation, students, technology, university.

JEL Classification: M13, M15

Received: 14 April 2023

Accepted: 13 June 2023

Published: 30 June 2023

Funding: There is no funding for this research.

Publisher: Academic Research and Publishing UG, Germany.

Founder: Sumy State University and Academic Research and Publishing UG (i.G.), Germany.

Cite as: Koe, W.-L., Rahim, M. R. A., & Mahphoth, M. H. (2023). Determinants of Technopreneurial Intention Among University Students: Individual Entrepreneurial Orientation (IEO) as Mediator. *Marketing and Management of Innovations*, 2, 185–195. <https://doi.org/10.21272/mmi.2023.2-17>



Introduction. Entrepreneurship plays a significant role in establishing and evolving business sectors and the growth and wealth of regions and nations (Hisrich et al., 2017). Moreover, it is needed to support the Fourth Industrial Revolution (IR 4.0) current trend. IR 4.0 focuses on digital technology, combining different techniques to make the existing products or services more advanced, such as using big data analytical, 4D printing and augmented reality (Davis, 2018). Thus, as technology grows and becomes more advanced, entrepreneurs need to follow and adapt to the transformation by using technology or digitalised systems in their businesses.

Today's entrepreneurs must convert their businesses from traditional to digital, such as e-commerce platforms. In Malaysia, the government has set up Malaysia Digital Economy Corporation (MDEC) to lead the digital transformation of the country's economy. MDEC is also vital in attracting world-class digital businesses and talents to invest in Malaysia under the Malaysia Digital strategic initiative (MDEC, 2022). Apart from MDEC, Small and Medium Enterprises Corporation (SME Corp) Malaysia has also initiated Women Netpreneur Program to enable women entrepreneurs to continuously tackle the challenge that emerged from IR 4.0, digitalisation and technological convergence (SME Corp, 2023). Undoubtedly, the use of technology and digitalisation in businesses have also bloomed during the COVID-19 pandemic era.

Undeniably, the application of technology in businesses could bring various benefits; that is the main reason for the Malaysian government to continuously encourage entrepreneurs to adopt technology and transform into technopreneurs. It is important to note that a technopreneur-ship combines technology and entrepreneurship. Technopreneurship has long been recognised as an important component of competitive advantage (Abdullah et al., 2013). Technopreneurs use technology as a catalyst for the main business line; they are risk-takers who develop new business ideas from technology mode (Nacu, C. M., and Avasilcai, 2014). They merge technology with people's talents and skills (Balachandran, 2018). It can be said that technopreneur-ship is the future trend of the modern and advanced business world. Although various strategies have been carried out, the establishments of new technology-based business entities are still slow in the process.

The Malaysian government is well aware of the importance of training the young generations to take up technology-based entrepreneurship. One of the efforts is offering entrepreneurship as a core subject for students in public universities (Rahim et al., 2015). The National Entrepreneurship Policy (NEP) 2030 clearly states that one of its five objectives is making entrepreneurship a preferred career choice. In addition, the Entrepreneurship Action Plan Higher Education Institutions (EAP-HEIs) 2021-2025 has also strategised to leverage innovation and technology in business and establish innovation, technology and digitally-driven businesses. Although the government has allocated many funds to developing technology-based entrepreneurs, the number of newly-formed technopreneurs still needs to grow.

Furthermore, as stated in EAP-HEIs 2021-2025, one of the issues and challenges in entrepreneurship development is that some students would prefer to take up entrepreneurship as a career. The low participation of youths in becoming technopreneurs would cause disadvantages to Malaysia. Eventually, the country would need to catch up to the developing current of IR 4.0.

It is a fact that developing technopreneurs is a challenging task. This is because technopreneurs need to be creative, innovative and well-versed in information-communication technology; and also be able to understand dimensions of high technology to produce products or services based on technology (Fowosire et al., 2017). Apart from providing sufficient knowledge about technology, a high level of intention towards technopreneurship is also important and could be considered the initial stage in developing competitive technopreneurs. However, technopreneurs' intention is still considered a relatively new research area in Malaysia and has yet to be fully explored. Therefore, the purpose of this study is to investigate the determinants of technopreneurial intention among university students.

Literature Review. Technopreneurship is a concept which involves merging technology ability with entrepreneurial talent and skill (Suradi et al., 2017). Technopreneurship is also known as establishing a new-technology-based firm (Colombo and Delmastro, 2001). An entrepreneur who uses technology as a catalyst for the main business line is known as a technopreneur. The technological entrepreneur is also a risk taker when developing a new business idea from technology mode (Nacu, C. M., and Avasilcai, 2014). In today's knowledge economy, technopreneur-ship has been recognised as an important part of competitive advantage (Abdullah et al., 2013). The new ideas that come from these technopreneurs will be interpreted in technological products and then sold in markets. Technology entrepreneurship is also related to forming new technology ventures (Jones-Evans, 1995).

In Malaysia, the development of technopreneurship is relatively new, and it has a lower level of acceptance as compared to America and other European countries in which the concept started in the early 1990s

(Colombo and Delmastro, 2001; Jelinek, 1996; Suradi et al., 2017). Technopreneurship is a significant term in today's IR4.0 era, whereby technology innovation is given top priority as the most current trend in the world. Relevant Malaysian governmental agencies have devised various strategies to encourage and support technology-based enterprises. For instance, MDEC has initiated Malaysia Tech Entrepreneur Program (MTEC), Malaysia External Trade Development Corporation (MATRADE) has implemented e-TRADE Program 2.0, and Malaysia Research Accelerator for Technology and Innovation (MRANTI) was established to escalate the commercialisation of technology. These agencies provide good opportunities, funds, business advisory services and physical infrastructures for Malaysians to explore, create and develop technology-based firms (IMoney, 2014). In addition, Majlis Amanah Rakyat (MARA) is another agency which actively engages in the development of technopreneurs based on Technical and Vocational Education and Training (TVET) (Suradi et al., 2017).

Undeniably, many efforts have been devoted to technopreneurship development in the country; however, the establishments of technology-based enterprises still need to be more satisfactory. Specifically, the number of young adults who take up technopreneurship as a career still needs to grow. Therefore, youths need to be encouraged to embark on technopreneurship. Cultivating positive intention towards technopreneurship is a significant initial stage in developing technopreneurs.

Entrepreneurial intention forms the foundations of new organisations (Krueger, 1993). As entrepreneurship occurs over time (Gartner et al., 1994), entrepreneurial intentions are considered the first step in developing a long-term process of founding an organisation. Technopreneurial intention is rather similar to entrepreneurial intention. The only difference between them is that the term entrepreneurial is widely used in business nature; meanwhile, technopreneurs are more specific in featuring technology-based entrepreneurs. This means that technopreneurial intention refers to a person's intention to own a business where the nature of business is a technology focused. It is an individual's psychological condition which can be explained by the Theory of Planned Behavior (TPB).

TPB, developed by Ajzen (1991), is an extension of the Theory of Reason Action (TRA) introduced by Fishbein and Ajzen (1975). Both theories stress that a person's behaviour is an outcome of intention. However, TPB further highlighted that intention is a function of attitude towards a behavioural outcome, public opinion (subjective norm) and control of behaviour (perceived behavioural control). To date, many studies have employed TPB in studying an individual's intention and behaviour; thus, this study also employed TPB as the underpinning theory and foundation of the dependent variable, technopreneurs intention.

As Ajzen (1991) explained, TPB has based on the philosophy of understanding that an individual's performance on certain behaviour depends on his or her intention relating to that behaviour in a specific context. When individuals show their intention, they will do it. However, it does not mean that they will perform the behaviour instantly at the same time as their intention; it might take time for that behaviour to happen. It is believed that intention is a good and influential predictor of behaviour (Armitage and Conner, 2001; Teo and Lee, 2010). Meanwhile, the intention is affected by attitude, social norms and perceived behavioural control (PBC). According to Ajzen (1991), attitude can be explained as the degree of favourable or unfavourable evaluation of behaviour. Subjective norms concerning the perceived normative specific reference group towards engaging or not engaging in a particular behaviour. In comparison, PBC can be regarded as the perceived ability to carry out a behaviour. It is related to self-efficacy in Bandura's Social Learning Theory (Bandura, 1977) and is used interchangeably with PBC in many previous studies.

As mentioned in the previous section, PBC or self-efficacy was one-factor affecting technopreneurial intention. Self-efficacy is «people's judgements of their capabilities to organise and execute courses of action required in attaining designated types of performance» (Bandura, 1986). It can be called self-belief or self-perceived ability to accomplish something (Bandura, 1997). As such, people will try something when they think they can do it and vice versa. In this study, self-efficacy consisted of general computer self-efficacy and Internet self-efficacy.

General computer self-efficacy is a fundamental construct of information technology which refers to an individual's judgment of competency across multiple computer application domains (Albashrawi and Alashoor, 2017). They further stated that there was a positive relationship between computer self-efficacy and entrepreneurial intention. Sitaridis and Kitsios (2019) identified computer self-efficacy as a measure of the general ability to use computers and software. They further concluded that students who gained a high level of computer self-efficacy would increase their entrepreneurial intention. Meanwhile, He and Freeman (2010) described computer self-efficacy as a set of beliefs about being able to perform tasks using a computer. They also found that computer self-efficacy determined an individual's attitude and career choice. Regarding

entrepreneurship research, Chen (2013) investigated college students and found that self-efficacy affected information technology entrepreneurial intention.

Internet self-efficacy can be defined as a Web user's self-perceived confidence and expectations of using the Internet (Wu and Tsai, 2006). It is the belief in one's ability to organise and implement Internet functions to complete certain tasks (Eastin and Rose, 2000; Hsu and Chiu, 2004). Previous studies have successfully proven the relationship between Internet self-efficacy and individual intention. For instance, Cong-Lem (2018) found that Internet self-efficacy was related to the intention to use the Internet as language learning. Eastin and Rose (2000) stated that prior Internet usage, experience and outcome expectancies were significantly related to Internet self-efficacy judgement.

General computer and Internet self-efficacy are two factors that are considered personal or individual. However, environmental or external factors should also be addressed in understanding technopreneurial intention. The surrounding business and societal environment that affect entrepreneurial activities and intentions can be collectively recognised as contextual elements (Indarti and Kristiansen, 2003; Setiobudi and Herdinata, 2018; Tran and Korflesch, 2016). In addition, the contextual element was recognised as an environmental factor related to the concept of entrepreneurship supports and barriers (Luthje and Franke, 2003; Schwarz et al., 2009). Nowadays, there is much research examining the influence of contextual elements on entrepreneurial intention, for example, Mat et al. (2015), Setiobudi and Herdinata (2018) and Tran and Korflesch (2016), to name a few. The three most noticeable aspects of the contextual element are access to capital, information accessibility, and social networking (Kristiansen and Indarti, 2004; Ramayah and Harun, 2005), and they are essential in motivating entrepreneurial intention.

Individual entrepreneur orientation (IEO) was developed based on firm-level entrepreneurial orientation (EO). IEO and EO have similar dimensions: innovativeness, risk-taking, proactiveness, autonomy and competitive aggressiveness. Ibrahim and Lucky (2014) and Robinson and Stubberud (2014) found a significant relationship between IEO and entrepreneurial intention. In addition, the research found that self-efficacy was an influencing factor in IEO (Mutluturk and Mardikyan, 2018; Khedhaouria et al., 2015). The relationships between self-efficacy, IEO and entrepreneurial intention were rather complex. Rahim et al. (2018) suggested that IEO could mediate the relationship between self-efficacy and entrepreneurial intention. The suggestion was supported by Martins and Perez (2020), which indicated that IEO significantly mediated between close environmental factors and entrepreneurial intention.

Based on the above discussions, this study further suggested the following research model (Figure 1) and hypotheses (H1 to H10).

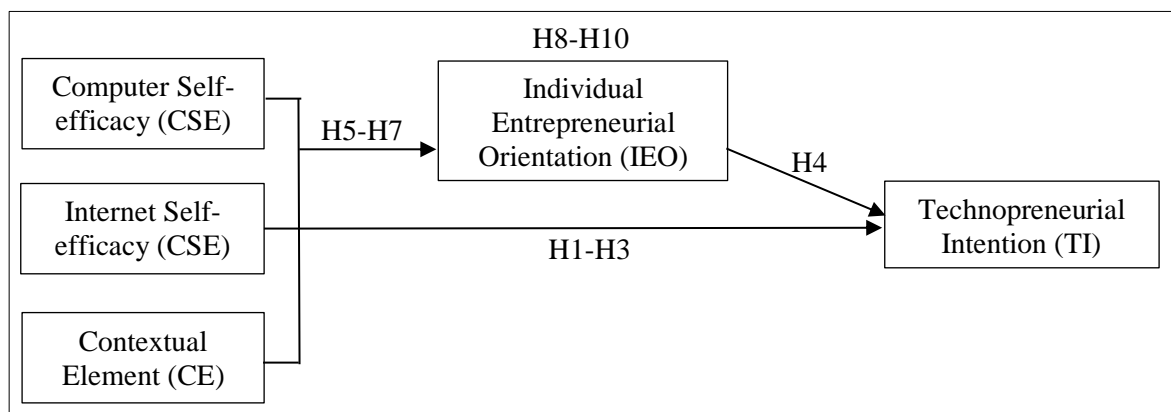

Figure 1. Research model

Sources: developed by the authors.

- H1: There is a positive relationship between CSE and TI.
- H2: There is a positive relationship between ISE and TI.
- H3: There is a positive relationship between CE and TI.
- H4: There is a positive relationship between IEO and TI.
- H5: There is a positive relationship between CSE and IEO.
- H6: There is a positive relationship between ISE and IEO.
- H7: There is a positive relationship between CE and IEO.
- H8: IEO mediates the relationship between CSE and TI.

H9: IEO mediates the relationship between ISE and TI.

H10: IEO mediates the relationship between CE and TI.

Methodology and research methods. This study was quantitative because all of its variables were measurable and quantifiable. As this was a cause-and-effect study, ten hypotheses were developed and tested statistically. The unit of analysis was an individual student selected from a local Malaysian university which offered entrepreneurship as a core subject. Specifically, a self-administered questionnaire was used to collect the desired data. It is worth mentioning that a single cross-sectional time frame was adopted for data collection.

The population of this study encompassed Malaysia's public university students. They were selected because they studied technology-related and entrepreneurship courses during their semesters. In addition, they would need to choose to be employed or start their own business soon after graduation. The population size was 5030 students. This study employed proportionate stratified random sampling in terms of sample selection technique. The elements of the population were categorised into strata according to the university's three campuses. Subsequently, samples were drawn proportionately from each stratum. Referring to Krejcie and Morgan's (1970) Sample Determination table, this study required a minimum of 357 subjects.

This study employed a quantitative research method; a survey questionnaire was utilised. In particular, a self-administered electronic questionnaire was used. All questionnaire items were adapted from previous studies to ensure reliability and validity. Seven items related to CSE were adapted from Aesaert et al. (2017) and Hatlevik et al. (2018); seven items for ISE were adapted from Lai (2008) and Wu and Tsai (2006); seven items for CE were adapted from Kristiansen and Indarti (2004), Taormina and Lao (2006) and Miranda et al. (2017); ten items for IEO were adapted from Bolton and Lane (2012) and, six items for TI were adapted from Linen and Chen (2019)—all items employed seven-point Likert Scale. As for the data collection process, the questionnaire link was distributed to respondents with the help of their lecturers before the classes began. The collected data were statistically analysed using covariance-based structural-equation modelling (CB-SEM) to test the hypotheses.

Results. This study distributed 450 questionnaires and successfully collected 360 responses at the end of the data collection process. Hence, the response rate of this study was 80.0%. The high response rate could be attributed to the data collection done with the help of lecturers. Missing data (or missing value) was not found in this study; thus, there were no significant problems concerning data invalidity. In terms of outliers, two cases were deleted. The remaining 358 responses have proceeded to subsequent analyses because they fulfilled the minimum sample size requirement. Since CB-SEM analysis requires the data to be normally distributed, this study employed skewness and Kurtosis to examine normality. The Skewness range is normal between -2 to +2, and the Kurtosis range should be around -7 to +7 (Hair et al., 2010; Kim, 2013). The data obtained normality because skewness and Kurtosis values recorded by each variable fell within the desired range.

Of the 358 respondents, more than half of them were female (n=218; 60.89%). Regarding the respondents' academic background, most of them studied in the business and management cluster (n=201; 56.15%). This cluster consisted of accountancy, business and management, information management and hotel and tourism management. About half of the respondents answered that no one in their family owned a business (n=207; 57.82%). Most of them (n=250; 69.83%) lived in urban areas. Most received financial assistance for the study (n=194; 54.19%).

It is important to ensure unidimensionality and that all fitness indices were met in evaluating the measurement model. Unfortunately, the initial model consisted of several items with low factor loadings (loading<0.50), and its fitness indices was below the cut-off values (GFI=0.617; AGFI=0.566; RMSEA=0.117; TLI=0.674; CFI=0.696). As such, a revised model was developed by eliminating items with factor loadings less than 0.50. Specifically, two items from CSE (i.e.: CSE6 and CSE7), four items from ISE (i.e.: ISE4, ISE5, ISE6 and ISE7), three items from CE (i.e.: CE1, CE2 and CE7), seven items from IEO (i.e.: IEO1, IEO5, IEO6, IEO7, IEO8, IEO9 and IEO10) and, one item from TI (i.e.: TI2) were deleted.

The revised model could be considered fit, and the values of fit indices are summarised in Table 1.

Table 1. Indices of model fit

Indices	Value	Decision
CMIN/DF	3.060	<5.00, achieved
GFI	0.886	< 0.90, slightly not achieved
AGFI	0.850	< 0.90, slightly not achieved
TLI	0.925	>0.90, achieved
CFI	0.936	>0.90, achieved
RMSEA	0.076	< 0.08, achieved

Sources: developed by the authors.

As shown, the normed chi-square (CMIN/DF) (3.060), TLI (0.925), CFI (0.936) and RMSEA (0.076) have successfully met the cut-off values. It was regretted that GFI (0.886) and AGFI (0.850) were slightly below the required values. However, Sharma et al. (2005) mentioned that GFI was affected by sample size and should not be used to determine the fit. Therefore, construct validity was achieved.

On the other hand, Table 2 shows the values of the standardised loading, average variance extracted (AVE), composite reliability (CR) and Cronbach's alpha (α). All items indicated loading values greater than 0.50. Meanwhile, all AVE values were greater than 0.50 (except AVE of CE), and all CR and α values were higher than 0.70. Although the AVE of CE was below 0.5, it was still deemed acceptable because its CR was greater than 0.60. Therefore, reliability and convergent validity were achieved.

Table 2. Loading, AVE, CR and Cronbach's alpha

Construct and Item	Loadings	AVE	CR	α
Computer Self-efficacy (CSE)		0.580	0.871	0.873
CSE 1	0.833			
CSE 2	0.845			
CSE 3	0.682			
CSE 4	0.820			
CSE 5	0.594			
Computer Self-efficacy (ISE)		0.858	0.948	0.867
ISE 1	0.887			
ISE 2	0.961			
ISE 3	0.929			
Contextual Element (CE)		0.486	0.788	0.840
CE 3	0.724			
CE 4	0.724			
CE 5	0.777			
CE 6	0.540			
Individual Entrepreneurial Orientation (IEO)		0.576	0.799	0.827
IEO 2	0.864			
IEO 3	0.595			
IEO 4	0.792			
Technopreneurial Intention (TI)		0.884	0.961	0.958
TI 1	0.833			
TI 3	0.845			
TI 4	0.682			
TI 5	0.820			
TI 6	0.594			

Sources: developed by the authors.

Table 3 illustrates the values of Pearson correlation, squared inter-construct correlation (SIC) (value shown in italics), and the square root of AVE (value shown in bold). As AVEs were greater than the corresponding SIC and the square root of AVE was greater than the next value across its row and column, discriminant validity was achieved.

Table 3. Correlation, squared interconstruct correlation and the square root of AVE

	CSE	ISE	CE	IEO	TI
CSE	0.762	<i>0.498</i>	<i>0.009</i>	<i>0.064</i>	<i>0.010</i>
ISE	0.698**	0.926	<i>0.029</i>	<i>0.087</i>	<i>0.020</i>
CE	0.094	0.169**	0.697	<i>0.272</i>	<i>0.376</i>
IEO	0.253**	0.295**	0.522**	0.759	<i>0.150</i>
TI	0.100	0.140**	0.613**	0.387**	0.940

CSE: computer self-efficacy; ISE: Internet self-efficacy; CE: contextual element; IEO: individual entrepreneurial orientation; TI: technopreneurial intention

** . Correlation is significant at the 0.01 level (2-tailed).

Sources: developed by the authors.

Figure 2 shows the structural model with model fit indices.

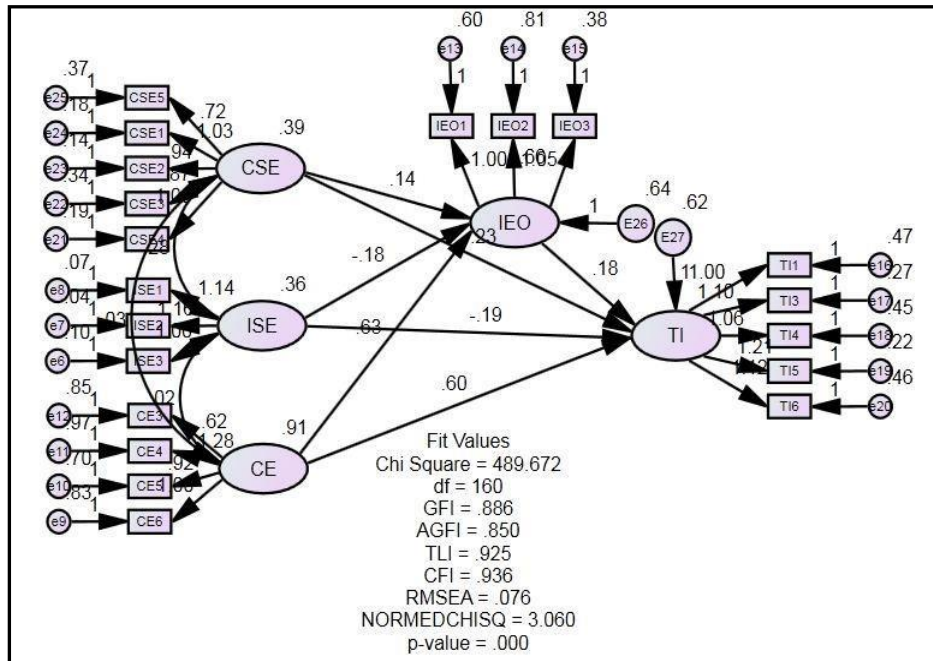

Figure 2. Structural model

Sources: developed by the authors.

Table 4 summarises the standardised estimates of direct effect and its significant level. CE was identified to have a positive and significant relationship with IEO and TI. Meanwhile, IEO significantly influenced TI. The other constructs, such as CSE and ISE, had no positive relationship with IEO and TI.

Table 4. Path analysis and decision

Path	Estimate	C.R	P	Decision
IEO ← CSE	0.089	0.998	0.318	Not significant
IEO ← ISE	-0.108	-1.239	0.215	Not significant
IEO ← CE	0.601	8.557	<0.001***	Significant
TI ← CSE	0.137	1.765	0.078	Not significant
TI ← ISE	-0.106	-1.408	0.159	Not significant
TI ← CE	0.538	7.124	<0.001***	Significant
TI ← IEO	0.173	2.579	<0.010**	Significant

Sources: developed by the authors.

Table 5 depicts the results of the bootstrap mediation analysis. The results revealed that IEO did not contribute to any significant mediation effect between CSE and TI ($p > 0.05$), as well as between ISE and TI ($p > 0.05$). However, IEO significantly mediated the relationship between CE and TI ($p < 0.05$).

Table 5. Bootstrap mediation analysis

Path	Estimates	Standardised Indirect Effect		Significance (BC)	Decision
		95% Confidence Interval Lower Bound	95% Confidence Interval Upper Bound		
TI ← IEO ← CSE	0.015	-0.004	0.061	0.217	Not significant
TI ← IEO ← ISE	-0.019	-0.066	0.002	0.136	Not significant
TI ← IEO ← CE	0.104	0.025	0.194	0.029*	Significant

Sources: developed by the authors.

Table 6 summarises the results of the hypotheses testing. Computer and Internet self-efficacy were not significant in influencing technopreneurial intention and individual entrepreneurial orientation; thus, H1, H2, H5 and H6 were unsupported. As Albashrawi and Alashoor (2020) pointed out, individuals who were good at computers and technology did not necessarily show interest in becoming entrepreneurs. Furthermore, Ratten

(2013) stressed that computer self-efficacy was important in determining an individual's performance in using technology innovation. True, people with high technological knowledge might be more interested in becoming technologists than entrepreneurs.

Meanwhile, a significant relationship was found between contextual elements, individual entrepreneurial orientation and entrepreneurial intention; hence, H3, H4 and H7 were supported. As supported by Indarti and Kristiansen (2003), Taormina and Lao (2006) and Mat et al. (2015), a person's decision to embark on entrepreneurship was influenced by contextual elements, such as access to capital, access to information and social network. Undeniably, a person's background factors would affect his or her career decision. In addition, previous scholars have identified a positive relationship between individual entrepreneurial orientation and entrepreneurial intention (e.g., Suartha and Suprpti, 2016; Koe, 2016). It is well understood that a person would become an entrepreneur when exhibiting entrepreneurial qualities and characteristics.

Table 6. Results of hypotheses testing

Hypothesis	Result
H1: There is a positive relationship between CSE and TI.	Not Supported
H2: There is a positive relationship between ISE and TI.	Not Supported
H3: There is a positive relationship between CE and TI.	Supported
H4: There is a positive relationship between IEO and TI.	Supported
H5: There is a positive relationship between CSE and IEO.	Not Supported
H6: There is a positive relationship between ISE and IEO.	Not Supported
H7: There is a positive relationship between CE and IEO.	Supported
H8: IEO mediates the relationship between CSE and TI.	Not Supported
H9: IEO mediates the relationship between ISE and TI.	Not Supported
H10: IEO mediates the relationship between CE and TI.	Supported

Sources: developed by the authors.

Regarding the mediation effect, individual entrepreneurial orientation did not significantly mediate the relationship between computer self-efficacy, Internet self-efficacy and technopreneurs' intention; thus, H8 and H9 were unsupported. The reason for obtaining such results could be attributed to the low influence of individual entrepreneurial orientation on respondents. The respondents may be more likely to be employed in private or public sectors. The result supported H10 because the mediating effect of individual entrepreneurial orientation between the contextual elements and technopreneurs' intention was significant. The result was parallel with studies by Kristiansen and Indarti (2004) and Ramayah and Harun (2005), which found that contextual elements or instrumental readiness influence entrepreneurial intention.

Conclusions. This study investigated the relationships between the independent variables: computer self-efficacy, Internet self-efficacy and contextual elements; individual entrepreneurial orientation (IEO) as the mediator variable and technopreneurs' intention as the dependent variable. Based on the results, computer and Internet self-efficacy were insignificant in developing entrepreneurial-orientated individuals with technopreneurs intentions. Meanwhile, contextual elements were a substantial factor in encouraging entrepreneurship among university students. In addition, IEO was an important mediator between the contextual elements and technopreneurs' intentions.

This study contributed to both literature and practice. This study confirmed the application of the Theory of Planned Behavior (TPB) and IEO in entrepreneurship research. It also supported the role of contextual elements in entrepreneurship studies. Practically, it highlighted the need to focus on contextual element factors in entrepreneurship development among university students. It also pointed out the misconception of computer and Internet self-efficacy in technopreneurs' intentions.

Author Contributions: conceptualization, W. L. K.; methodology, W. L. K. and M. R. A. R.; software, M. R. A. R. and M. H. M.; validation, M. H. M.; formal analysis, M. R. A. R.; investigation, M. R. A. R.; resources, W. L. K.; data curation, M. H. M.; writing-original draft preparation, W. L. K. and M. R. A. R.; writing-review and editing, M. H. M.; visualization, W. L. K.; supervision, W. L. K.; project administration, W. L. K. and M. H. M.

Conflicts of Interest: Authors declare no conflict of interest.

Data Availability Statement: Not applicable.

Informed Consent Statement: Informed consent was obtained from all subjects involved in the study.

References

- Abdullah, S., Rahim, M. S., & Mohd Osman, M. H. (2013). Key influencing factors for technopreneur development and incubation program. [\[Google Scholar\]](#)
- Aesaert, K., Voogt, J., Kuiper, E., & van Braak, J. (2017). Accuracy and bias of ICT self-efficacy: An empirical study into students' over- and underestimation of ICT competencies. *Computers in human behaviour*, 75, 92-102. [\[Google Scholar\]](#) [\[CrossRef\]](#)
- Ajzen, I. (1991). The theory of planned behaviour. *Organisational behaviour and human decision processes*, 50(2), 179-211. [\[Google Scholar\]](#) [\[CrossRef\]](#)
- Albashrawi, M., & Alashoor, T. M. (2017). The role of IT on entrepreneurial intention: The effect of general computer self-efficacy and computer anxiety. [\[Google Scholar\]](#)
- Armitage, C. J., & Conner, M. (2001). Efficacy of the theory of planned behaviour: A meta-analytic review. *British Journal of social psychology*, 40(4), 471-499. [\[Google Scholar\]](#) [\[CrossRef\]](#)
- Balachandran, B. V. (2018). The next big thing in the start-up ecosystem—technopreneurship. *Entrepreneur Media, Inc.* [\[Google Scholar\]](#)
- Bandura, A. (1977). Self-efficacy: Toward a unifying theory of behavioural change. *Psychological review*, 84(2), 191. [\[Google Scholar\]](#) [\[CrossRef\]](#)
- Bandura, A. (1986). Social foundations of thought and action. *Englewood Cliffs, NJ*, 1986(23-28). [\[Google Scholar\]](#)
- Bandura, A. (1997). *Self-efficacy: The exercise of control*. Freeman.
- Bolton, D. L., & Lane, M. D. (2012). Individual entrepreneurial orientation: Development of a measurement instrument. *Education+ Training*, 54(2/3), 219-233. [\[Google Scholar\]](#) [\[CrossRef\]](#)
- Chen, L. (2013). IT entrepreneurial intention among college students: An empirical study. *Journal of Information Systems Education*, 24(3), 233-242. Retrieved from [\[Link\]](#)
- Colombo, M. G., & Delmastro, M. (2001). Technology-based entrepreneurs: Does the Internet make a difference? *Small Business Economics*, 16, 177-190. [\[Google Scholar\]](#) [\[CrossRef\]](#)
- Cong-Lem, N. (2018). Online self-regulated learning, internet self-efficacy, and intention to use the Internet for language learning. In *Proceedings of the 3rd International Conference on English Language Teaching*, (2018) (pp. 121-130). [\[Google Scholar\]](#)
- Davis, G. (2018). *Industrial Revolution 4.0*. Manufacturing Global.
- Eastin, M. S., & LaRose, R. (2000). Internet self-efficacy and the psychology of the digital divide. *Journal of computer-mediated communication*, 6(1), JCMC611. [\[Google Scholar\]](#) [\[CrossRef\]](#)
- Fishbein, M., & Ajzen, I. (1977). Belief, attitude, intention, and behaviour: An introduction to theory and research. [\[Google Scholar\]](#) [\[CrossRef\]](#)
- Fowosire, R. A. (2017). Technopreneurship: a view of technology, innovations and entrepreneurship. *Global Journals of Research in Engineering*, 17(F7), 41-46. [\[Google Scholar\]](#)
- Gartner, W. B., Shaver, K. G., Gatewood, E., & Katz, J. A. (1994). Finding the entrepreneur in entrepreneurship. *Entrepreneurship theory and practice*, 18(3), 5-9. [\[Google Scholar\]](#) [\[CrossRef\]](#)
- Hair, J. F., Black, B., Babin, B., Anderson, R.E., & Tatham, R.L. (2010). *Multivariate data analysis*. Prentice Hall.
- Hatlevik, O. E., Throndsen, I., Loi, M., & Gudmundsdottir, G. B. (2018). Students' ICT self-efficacy and computer and information literacy: Determinants and relationships. *Computers & Education*, 118, 107-119. [\[Google Scholar\]](#) [\[CrossRef\]](#)
- He, J., & Freeman, L. A. (2010). Understanding the formation of general computer self-efficacy. *Communications of the Association for Information Systems*, 26(1), 12. [\[Google Scholar\]](#) [\[CrossRef\]](#)
- Hisrich, R. D., Peters, M. P., & Shepherd, D. A. (2017). *Entrepreneurship*. 10th edition. [\[Google Scholar\]](#)
- Hsu, M. H., & Chiu, C. M. (2004). Internet self-efficacy and electronic service acceptance. *Decision support systems*, 38(3), 369-381. [\[Google Scholar\]](#) [\[CrossRef\]](#)
- Ibrahim, N. A., & Lucky, E. O. I. (2014). Relationship between entrepreneurial orientation, entrepreneurial skills, environmental factor and entrepreneurial intention among Nigerian students in UUM. *Entrepreneurship and Innovation Management Journal*, 2(4), 203-213. [\[Google Scholar\]](#)
- IMoney. (2014, November 19). *Raising technopreneurs in Malaysia*. IMoney Learning Center.
- Indarti, N., & Kristiansen, S. (2003). Determinants of entrepreneurial intention. *Gadjah Mada International Journal of Business*, 5(1), 79-95. [\[Google Scholar\]](#) [\[CrossRef\]](#)
- Jelinek, M. (1996). 'Thinking Technology' in mature industry firms: understanding technology entrepreneurship. *International Journal of Technology Management*, 11(7-8), 799-813. [\[Google Scholar\]](#)

Jones-Evans, D. (1995). A typology of technology-based entrepreneurs: A model based on previous occupational background. *International Journal of Entrepreneurial Behavior & Research*, 1(1), 26-47. [\[Google Scholar\]](#) [\[CrossRef\]](#)

Khedhaouria, A., Gurau, C., & Torrès, O. (2015). Creativity, self-efficacy, and small-firm performance: the mediating role of entrepreneurial orientation. *Small Business Economics*, 44, 485-504. [\[Google Scholar\]](#) [\[CrossRef\]](#)

Kim, H. Y. (2013). Statistical notes for clinical researchers: assessing normal distribution (2) using skewness and Kurtosis. *Restorative dentistry & endodontics*, 38(1), 52-54. [\[Google Scholar\]](#) [\[CrossRef\]](#)

Koe, W. L. (2016). The relationship between Individual Entrepreneurial Orientation (IEO) and entrepreneurial intention. *Journal of Global Entrepreneurship Research*, 6, 1-11. [\[Google Scholar\]](#) [\[CrossRef\]](#)

Krejcie, R. V., & Morgan, D. W. (1970). Determining sample size for research activities. *Educational and psychological measurement*, 30(3), 607-610. [\[Google Scholar\]](#) [\[CrossRef\]](#)

Kristiansen, S., & Indarti, N. (2004). Entrepreneurial intention among Indonesian and Norwegian students. *Journal of enterprising culture*, 12(01), 55-78. [\[Google Scholar\]](#) [\[CrossRef\]](#)

Krueger, N. (1993). The impact of prior entrepreneurial exposure on perceptions of new venture feasibility and desirability. *Entrepreneurship theory and practice*, 18(1), 5-21. [\[Google Scholar\]](#) [\[CrossRef\]](#)

Lai, M. L. (2008). Technology readiness, internet self-efficacy and computing experience of professional accounting students. *Campus-Wide Information Systems*. [\[Google Scholar\]](#) [\[CrossRef\]](#)

Linan, F., & Chen, Y. W. (2009). Development and cross-cultural application of a specific instrument to measure entrepreneurial intentions. *Entrepreneurship theory and practice*, 33(3), 593-617. [\[Google Scholar\]](#) [\[CrossRef\]](#)

Luthje, C., & Franke, N. (2003). The 'Making of an Entrepreneur: Testing a model of entrepreneurial intent among Engineering students at MIT. *R&d Management*, 33(2), 135-147. [\[Google Scholar\]](#) [\[CrossRef\]](#)

Malaysia Digital Economy Corporation (MDEC). (2022). *Leading Malaysia's Digital Economy*. Retrieved from [\[Link\]](#)

Martins, I., & Perez, J. P. (2020). Testing mediating effects of individual entrepreneurial orientation on the relation between close environmental factors and entrepreneurial intention. *International Journal of Entrepreneurial Behavior & Research*, 26(4), 771-791. [\[Google Scholar\]](#) [\[CrossRef\]](#)

Mat, S. C., Maat, S. M., & Mohd, N. (2015). Identifying factors that affect the entrepreneurial intention among engineering technology students. *Procedia-Social and Behavioral Sciences*, 211, 1016-1022. [\[Google Scholar\]](#) [\[CrossRef\]](#)

Nacu, C. M., & Avasilcai, S. (2014). Environmental factors influencing technological entrepreneurship: research framework and results. *Procedia-Social and Behavioral Sciences*, 109, 1309-1315. [\[Google Scholar\]](#) [\[CrossRef\]](#)

Miranda, F. J., Chamorro-Mera, A., & Rubio, S. (2017). Academic entrepreneurship in Spanish universities: An analysis of the determinants of entrepreneurial intention. *European research on management and business economics*, 23(2), 113-122. [\[Google Scholar\]](#) [\[CrossRef\]](#)

Mutlurk, M., & Mardikyan, S. (2018). Analysing factors affecting the individual entrepreneurial orientation of university students. *Journal of Entrepreneurship Education*, 21(1), 1-16. [\[Google Scholar\]](#)

Rahim, A. W. P. A. (2018). The relationship of individual creativity with entrepreneurial intention via individual entrepreneurial orientation (IEO). *International Journal of Innovation and Business Strategy (IJIBS)*, 9(1). [\[Google Scholar\]](#)

Rahim, H. L., Kadir, M. A. B. A., Abidin, Z. Z., Junid, J., Kamaruddin, L. M., Lajin, N. F. M., ... & Bakri, A. A. (2015). Entrepreneurship education in Malaysia: A critical review. *Journal of Technology Management and Business*, 2(2). [\[Google Scholar\]](#)

Ramayah, T., & Harun, Z. (2005). Entrepreneurial intention among the student of Universiti Sains Malaysia (USM). *International Journal of Management and Entrepreneurship*, 1(1), 8-20. [\[Google Scholar\]](#)

Ratten, V. (2013). Cloud computing: A social cognitive perspective of ethics, entrepreneurship, technology marketing, computer self-efficacy and outcome expectancy on behavioural intentions. *Australasian Marketing Journal*, 21(3), 137-146. [\[Google Scholar\]](#) [\[CrossRef\]](#)

Schwarz, E. J., Wdowiak, M. A., Almer-Jarz, D. A., & Breitenacker, R. J. (2009). The effects of attitudes and perceived environment conditions on students' entrepreneurial intent: An Austrian perspective. *Education+ Training*. [\[Google Scholar\]](#) [\[CrossRef\]](#)

Setiobudi, A., & Herdinata, C. (2018). The difference in entrepreneurial intention in generations x, y, and z. *International Journal of Academic Research in Business and Social Sciences*, 8(7), 48-57. [[Google Scholar](#)] [[CrossRef](#)]

Sharma, S., Mukherjee, S., Kumar, A., & Dillon, W. R. (2005). A simulation study to investigate the use of cut-off values for assessing model fit in covariance structure models. *Journal of Business Research*, 58(7), 935-943. [[Google Scholar](#)] [[CrossRef](#)]

Sitaridis, I. (2019, April). The effect of computer self-efficacy on entrepreneurial aspirations of students. In *2019 IEEE Global Engineering Education Conference (EDUCON)* (pp. 685-688). IEEE. [[Google Scholar](#)] [[CrossRef](#)]

SME Corporation Malaysia (SME Corp). (2023). *Women Netpreneur Programme*.

Suartha, N., & Suprpti, N. W. S. (2016). Entrepreneurship for students: The relationship between individual entrepreneurial orientation and entrepreneurial intention. *European Journal of Business and Management*, 8(11), 45-52. [[Google Scholar](#)]

Suradi, S., Yasin, R. M., & Rasul, M. S. (2017). Increasing technopreneurs for a developing nation: The majlis amanah rakyat (MARA) experience. *Journal of Technical Education and Training*, 9(1). [[Google Scholar](#)]

Taormina, R. J., & Lao, S. K. M. (2007). Measuring Chinese entrepreneurial motivation: Personality and environmental influences. *International Journal of Entrepreneurial Behavior & Research*, 13(4), 200-221. [[Google Scholar](#)] [[CrossRef](#)]

Teo, T., & Lee, C.B. (2010). Explaining the intention to use technology among student teachers: An application of the theory of planned behaviour (TPB). *Campus-Wide Information Systems*, 27(2), 60-67. [[CrossRef](#)]

Tran, A. T., & Von Korfflesch, H. (2016). A conceptual model of social entrepreneurial intention based on the social cognitive career theory. *Asia Pacific Journal of Innovation and Entrepreneurship*. [[Google Scholar](#)] [[CrossRef](#)]

Wu, Y. T., & Tsai, C. C. (2006). University Students' Internet Attitudes and Internet Self-Efficacy: A Study at Three Universities in Taiwan. *Cyberpsychology & behaviour*, 9(4), 441-450. [[Google Scholar](#)] [[CrossRef](#)]

Вей-Лоон Кое, Ph.D., Технологічний університет МАРА, Малайзія

Мохд Русуді Абдул Рахім, Технологічний університет МАРА, Малайзія

Мохд Налім Махпхотх, Ph.D., Технологічний університет МАРА, Малайзія

Наміри студентів університетів займатися технологічним підприємництвом: основні детермінанти впливу

Технологічне підприємництво відіграє важливу роль у сприянні інноваціям у бізнесі, особливо в епоху Четвертої промислової революції. Незважаючи на різноманітні зусилля та стратегії, розроблені урядом Малайзії для розвитку молодих підприємців у сфері технологій, все ще існує потреба у більшій кількості нових технологічних підприємств. Відмова студентів навчатися на спеціальностях, присвячених підприємницькій діяльності, залишається перманентною проблемою і викликом для країни. Метою даного дослідження є вивчення факторів, що визначають наміри студентів університетів навчатися та займатися технологічним підприємництвом. Об'єктом дослідження були обрані студенти публічного університету в Малайзії. Загальна кількість студентів, що взяли участь у дослідженні, становила 5030 осіб. За допомогою пропорційно-стратифікованої випадкової вибірки було обрано 358 студентів для участі в опитуванні. Методичним інструментарієм проведеного дослідження стали методи структурних рівнянь на основі коваріацій (СВ-SEM). Емпіричні результати підтвердили, що контекстуальні елементи, такі як доступ до капіталу, інформації та соціальних мереж, мають значущий та позитивний вплив на наміри студентів займатися технологічним підприємництвом. Однак комп'ютерна та Інтернет самоефективність не виявили значущого впливу на наміри студентів. Дослідження емпірично підтверджує та теоретично доводить, що контекстуальні елементи є важливими для сприяння та розвитку технологічного підприємництва. Результати проведеного дослідження розкривають модель розуміння та підтримки намірів студентів займатися технологічним підприємництвом. Емпіричні результати дослідження допомагають уряду знайти значущі зовнішні фактори, що впливають на наміри студентів займатися технологічним підприємництвом.

Ключові слова: підприємництво, мотивація, студенти, технології, університет.