

ENHANCING VALUE CO-CREATION THROUGH THE LENS OF DART MODEL, INNOVATION, AND DIGITAL TECHNOLOGY: AN INTEGRATIVE SUPPLY CHAIN RESILIENT MODEL

Omima Abdalla Abdalatif,  ORCID: <https://orcid.org/0000-0002-2525-2955>

Ph.D., University of Jeddah, Saudi Arabia

Mohammad Ali Yamin,  ORCID: <https://orcid.org/0000-0002-6944-6866>

Ph.D., Associate Professor, University of Jeddah, Saudi Arabia

Corresponding author: Mohammad Yamin, mayameen@uj.edu.sa

Type of manuscript: research paper

Abstract: *The global supply chain process has been badly affected by the COVID-19 pandemic. Consequently, firms search for factors that influence supply chain resilience and improve firm operational performance. The current research develops an integrated resilient supply chain model that combines factors underpinned DART model, innovation, digital technology, and value co-creation to investigate supply chain resilience during the COVID-19 pandemic. The research framework was empirically tested with a data set of 329 responses from employees working in logistics firms. The study find that supply chain resilience is determined by value co-creation, the DART model, innovation, and digital technology. The factors underpinning the DART model, including dialogue, access, risk assessment, and transparency, have positively impacted value co-creation. The structural model shows that dialogue has a positive impact on developing value co-creation between manufacturing firms and stakeholders, Empirical investigation revealed that value co-creation in supply chain operations is estimated by dialogue, access, risk assessment, transparency, innovation, and digital technology and revealed substantial variance R^2 71.9% in measuring value co-creation. This research is significant as it develops a resilient supply chain model with the combination of the DART model, innovation, digital technology, and value co-creation and investigates supply chain resilience during the COVID-19 pandemic. Although current research contributes to theory, practice, and method, disclosing research limitations opens numerous avenues for future researchers. This study does not claim to include all factors that impact the value co-creation process in supply chain operations. For instance, other factors, such as IT infrastructure, commitment, and integrative quality, may positively influence value co-creation. Second, supply chain resilience is determined by value co-creation and network capability. Therefore, the research encourages academicians and policymakers to investigate the supply chain resilience phenomenon with other market-oriented facts. future researchers are suggested to investigate the current research model in longitudinal method.*

Keywords: COVID-19, dialogue, network capability, resilience, risk assessment, transparency.

JEL Classification: M15, R41, O35

Received: 20 September 2022 **Accepted:** 17 December 2022 **Published:** 30 December 2022

Funding: This work was funded by the University of Jeddah, Jeddah, Saudi Arabia, under grant No. (UJ-21-DR-100). The authors, therefore, acknowledge with thanks the University of Jeddah technical and financial support.

Publisher: Sumy State University

Cite as: Abdalatif, O., & Yamin, M. A. (2022). Enhancing Value Co-Creation Through the Lens of DART Model, Innovation, and Digital Technology: An Integrative Supply Chain Resilient Model. *Marketing and Management of Innovations*, 4, 30-44. <https://doi.org/10.21272/mmi.2022.4-04>



Copyright: © 2022 by the author. Licensee Sumy State University, Ukraine. This article is an open access article distributed under the terms and conditions of the Creative Commons Attribution (CC BY) license (<https://creativecommons.org/licenses/by/4.0/>).

Introduction. The complexity of business operations, market expansion, and rising uncertainty have reaffirmed that logistics operations are not limited to transporting inventory from production point to consumption (Fernando and Chukai, 2018). Due to globalization, customers have more choices to switch from one product to another (Fernando and Chukai, 2018). Nevertheless, firms can hold customers by creating value co-creation (Sinkovics et al., 2018). According to Green et al. (2008), a value co-creation strategy is a resilient strategy that holds customers for a long time and boosts firm performance. Similarly, earlier studies have emphasized that organizations looking for long-term inter- and intra-organizational relationships should focus on developing value co-creation in logistics operations (Grandy and Levit, 2015; Sinkovics et al., 2018; Tian et al., 2021; Utami et al., 2021). Value co-creation is the extent to which mutual values are expanded through communication and ideas for achieving competitive advantages (Fernando and Chukai, 2018). According to Sinkovics et al. (2018), value co-creation can create a visible difference between a firm and its rivals. It should be examined in the supply chain context. Although prior studies have developed a strong linkage between value co-creation and firm performance Partouche-Sebban et al. (2021); Tian et al. (2021), the relationship between value co-creation and supply chain resilience is yet to be investigated.

Supply chain resilience is an essential factor in supply chain upheavals, disruption, and unforeseen events (Brandon-Jones et al., 2014). Resilience occurs when a firm continues its operations during the disruption of the supply chain (Bhamra et al., 2011). Earlier studies have emphasized that organizations should have resilience in the supply chain process to survive in a competitive environment (Blackhurst et al., 2011; Bode et al., 2011; Brandon-Jones et al., 2014; Karmaker et al. al., 2021). In the current scenario wherein the COVID-19 pandemic has disrupted business operations badly, resilience is an important factor for organization survival (Karmaker et al., 2021; de Sousa Jabbour et al., 2020). Authors like Brandon-Jones et al. (2014) stated that resilience enhances the capability of a firm to recover its operations quickly after being disrupted. Except for Ju et al. (2021) study, little has been discussed about the linkage between the DART model, value co-creation, and supply chain resilience. This research fills the gap in this context and develops an integrated resilient supply chain model with factors underpinning the DART model and value co-creation. It investigates supply chain resilience during the COVID-19 pandemic. The DART model comprises four main components: dialogue, access, risk assessment, and transparency. It has shown a direct influence on developing value co-creation (Ju et al., 2021; Prahalad and Ramaswamy, 2004). The current research is significant as it investigates value co-creation and supply chain resilience with an integrative research model. In addition, the moderating effect of network capability is examined between value co-creation and supply chain resilience. The following section develops the conceptual linkage between predictors and criterion variables.

Literature review. The DART model is established by Prahalad and Ramaswamy (2004). It sheds light on the value co-creation process of customers and firms. The value co-creation process enables firms to understand customer behavior, needs mutually, wants, demands, and service functions (Fernando and Chukai, 2018; Yamin, 2020a). The DART model comprises four main components: dialogue, access, risk assessment, and transparency (Pralhad and Ramaswamy, 2004). Dialogue is a process in which customers engage in product designing, production, and delivery (Singh, 2022; Yamin and Mahasneh, 2018; Yazdanparast et al., 2010). Access is characterized by customers exchanging ideas to improve the supply chain process (Ramaswamy and Ozcan, 2018). Similarly, transparency in logistics operations is essential for creating value co-creation (Pralhad and Ramaswamy, 2004; Yazdanparast et al., 2010). Earlier studies have confirmed the effectiveness of factors underpinned DART model in creating value co-creation among manufacturer and supply chain stakeholders (Fernando and Chukai, 2018; Prahalad and Ramaswamy, 2004; Ren et al., 2015; Yazdanparast et al., 2010). Recently authors like Fernando and Chukai (2018) have revealed the significant impact of dialogue, access, risk assessment, and transparency toward sustainable supply chain logistics. According to Saarijärvi et al. (2013) transparency in sharing knowledge benefits both customers and firms and enriches confidence. It is noted that sharing information between manufacturer and supply chain partners give a better chance to evaluate risk (Fernando and Chukai, 2018). Following the above arguments and consistent with earlier studies conducted by Ramaswamy and Ozcan (2018); Saarijärvi et al. (2013); Yazdanparast et al. (2010), the hypotheses are proposed as follows:

- H1: Dialogue in the supply chain process significantly impacts value co-creation.
- H2: Access in the supply chain process significantly impacts value co-creation.
- H3: Risk assessment significantly impacts value co-creation.
- H4: Transparency significantly impacts value co-creation.

Innovation in the supply chain is seen as implementing creative and new ideas to bring harmony to supply chain operations (Aamer et al., 2021; Afraz et al., 2021). Innovation substantially impacts supply chain performance and customer satisfaction (Afraz et al., 2021; Agarwal and Selen, 2009; Pillai and Sivathanu, 2020). Implementing creative and innovative ideas create a competitive edge for companies (Agarwal and Selen, 2009; Sinkovics et al., 2018). Regarding value co-creation, innovative ideas ease supply chain operations and reward all stakeholders (Singh and Singh, 2019; Sinkovics et al., 2018). The use of digital technology enhances supply chain integration (Afraz et al., 2021; Masa'deh et al., 2018). Earlier studies have confirmed that digital technology improves a firm operational performance and customer experience, enrich stakeholder relationship, and enhance value co-creation (Cichosz et al., 2020; Hopkins, 2021; Ivanov et al., 2019; Liu et al., 2020; Sinkovics et al., 2018). Authors like Ju et al. (2021) have confirmed the positive impact of digital technology in predicting value co-creation. Following the above arguments and backed up by earlier studies conducted by Afraz et al. (2021); Cichosz et al. (2020); Ivanov et al. (2019); Liu et al. (2020); Sinkovics et al. (2018), the hypotheses are proposed as follows:

H5: Innovation in the supply chain significantly impacts value co-creation.

H6: Digital technology significantly impacts value co-creation.

The term network capabilities are the extent to wherein a firm initiates, utilizes, and maintains relationships with external partners instead of relying on single relationships and reliance (Mitrega et al., 2012; Partanen et al., 2020). The network capability is a combination of inter-firm coordination, partner knowledge, relationship skills, and internal communication of a firm to facilitate supply chain operations (Andriopoulos and Lewis, 2009; Bader and Mohammad, 2019; Kauppila, 2015). Literature has revealed the substantial influence of network capability in determining supply chain operations which in turn enhances firm performance (Andriopoulos and Lewis, 2009; Kauppila, 2015; Partanen et al., 2020; Paulraj et al., 2008; Semrau and Sigmund, 2012). According to Schreiner et al. (2009), network capability increases commitment and bonding between internal and external supply chain partners, which adds value to supply chain operations. A recent study conducted by Partanen et al. (2020) disclosed that the moderating effect of network capability reduces the negative effect between supply chain ambidexterity and firm performance. Following the above arguments (Schreiner et al., 2009; Partanen et al., 2020), research assumed that network capability moderates the relationship between value co-creation and supply chain resilience. Thus, the following hypotheses are proposed:

H7: Value co-creation significantly impacts supply chain resilience.

H8: Network capability has a moderating effect between value co-creation and supply chain resilience.

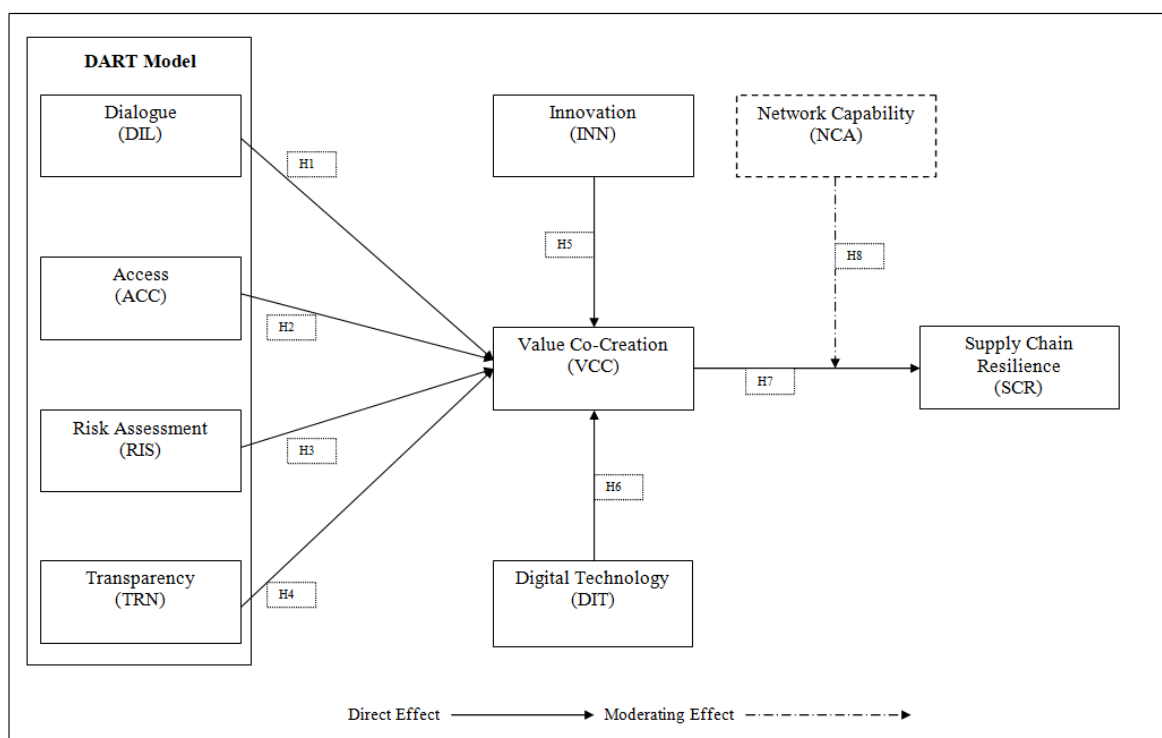

Figure 1. Theoretical framework

Sources: developed by the authors.

Methodology and research methods. The present study incorporates factors underpinned by the DART model, network capability, innovation, and digital technology to investigate value co-creation in supply chain and supply chain resilience. Constructs items were selected from a previously developed scale and measured with 7 points Likert scale indicating 1 for «strongly disagree» to 7 for «strongly agree». It is consistent with Rahi (2017) and Rowley (2014). Scale items for network capability were adopted from Partanen et al. (2020). Supply chain resilience items were adopted from Singh and Singh (2019). Scale items for constructing digital technology were adopted from Cichosz et al. (2020). In the logistics context items for value, co-creation was adopted from Ren et al. (2015). Innovation scale items were adopted from Sinkovics et al. (2018). Therefore, constructs items underpinned by the DART model, including dialogue, access, risk assessment, and transparency, were adopted from Fernando and Chukai (2018) and Prahalad and Ramaswamy (2004). The face validity of the questionnaire was confirmed by the expert panel in the same field. Experts agreed with the contents. Nevertheless, it advised adding resilience and co-creation words in all items to make the instrument meaningful. Thus, scale items were adapted in the context of value co-creation and supply chain resilience.

The quantitative research approach is used in this research. This research aims to investigate factors that enhance value co-creation and supply chain resilience in an organization. Therefore, the literature has synthesized factors underpinning the DART model, innovation, and digital technology to investigate value co-creation and supply chain phenomena in logistics firms. For testing the assumptions, data was collected through structured questionnaires. The research questionnaire of this study contains respondents' demographic characteristics and construct indicators. The population of this research is employees working in logistics firms and manufacturing companies in Saudi Arabia. The sample size is selected through prior power analysis using G-power software consistent with earlier studies (Rahi, 2017; Rahi et al., 2021; Sweiss and Yamin, 2020; Yamin, 2019). The power analysis results suggest the maximum size required to test the research model is 280 responses.

Nevertheless, the research distributed 500 questionnaires among employees working in logistics and manufacturing companies. Research questionnaires are distributed using a convenience sampling approach, a non-random sampling approach supported by prior studies (Rahi and Abd. Ghani, 2018; Ramaswamy and Ozcan, 2018; Saarijärvi et al., 2013; Yazdanparast et al., 2010). The research survey was administered during the COVID-19 pandemic. Therefore, online tools have been used for data collection. The rationale behind conducting an online survey is to minimize physical contact between employees and researchers, lowering the chances of getting affected by contagious COVID-19. During the online survey, research questionnaires were forwarded to employees using social media platforms, including Facebook, LinkedIn, and Twitter, and via direct emails. Among 500 questionnaires, 329 responses were retrieved from respondents with an adequate response rate 66%. Overall, the research model of this study is tested with 329 responses. The detail of the data analysis, including common method variance bias, is given in the following section.

In this research, data were collected using quantitative research strategies. According to Hair et al. (2014), common method bias is raised often in the survey based research. Therefore, data should be verified before inferential analysis. In survey-based studies, literature has suggested incorporating Harman single factor analysis (Rahi and Khan, et al., 2020; Yamin and Alyoubi, 2020). Therefore, the Harman single factor analysis was employed to test the common method variance bias. This test recommends that the threshold value of the first factors must be lower than 50%, representing data have no potential threat from common method bias (Podsakoff et al., 2003; Rahi and Khan, et al., 2020; Yamin, 2020b). Results of the Harman single-factor analysis (Table 1) have shown that the maximum variance explained by the first factor is only 39% and less than the threshold value (50%). These findings established that the data set has no biased values. It is valid for statistical analysis.

Table 1. Harman's analysis using a single-factor solution

Factors	Initial Eigenvalues			Extraction Sums of Squared Loadings		
	Total	% of Variance	Cumulative %	Total	% of Variance	Cumulative %
1	12.746	39.831	39.831	12.746	39.831	39.831

Sources: developed by the authors.

The research model (Figure 1) was tested with structural equation modeling (SEM). Structural equation modeling includes two approaches to assess data: co-variance-based (CV-SEM) and partial least squares (PLS-SEM). Following research objectives and consistent with prior research (Rahi et al., 2021; Yamin and Alyoubi, 2020) partial least square approach (PLS-SEM) was selected in this study for data analysis. SEM

computes data in two stages: first, through a measurement model, and second, using a structural model. The detail of these two stages is given in the following sections.

The first step after data screening is to confirm constructs reliability, convergent validity, instrument reliability, and discriminant validity of the constructs with measurement model. For constructing reliability, the research followed the guidelines provided by Rahi et al. (2018). It is recommended that Cronbach's alpha (CA) and composite reliability values must be higher than $>.70$ to achieve adequate reliability of the constructs (Rahi et al., 2018). Therefore, instrument reliability threshold values should be higher than $>.60$, consistent with previous studies (Rahi et al., 2018; Sweiss and Yamin, 2020). In addition to that, average variance extracted values were considered to achieve convergent validity of the measure following the criterion that AVE must be higher than $.50$ for adequate convergent validity (Rahi et al., 2018; Sweiss and Yamin, 2020). Table 2 exhibits the results of the measurement model.

Table 2. Measurement model

Indicator	Loadings	CA	CR	AVE
ACC1: This firm uses the latest tools to maintain client and logistic managers' relationships.	0.842	0.802	0.870	0.627
ACC2: This firm share new product development information with stakeholders without any obstacle.	0.745			
ACC3: This firm has improved the quality of logistics services and operations through easy access.	0.798			
ACC4: The active involvement of clients helps firms to improve logistic services.	0.778			
DIL1: This firm engages clients in logistics services through dialogue.	0.796	0.750	0.857	0.666
DIL2: This firm understands clients' needs through dialogue.	0.827			
DIL3: The knowledge is shared through dialogue between firms and clients.	0.825			
DIT1: Digital technology is essential for logistics transformation.	0.840	0.857	0.903	0.699
DIT2: Digital technology brings ease in collecting customer and market information.	0.841			
DIT3: This firm has improved logistics services using digital technology.	0.814			
DIT4: This firm uses digital technology to process transaction information.	0.850			
INN1: Our firm uses innovative tools to process logistic operations.	0.844	0.719	0.843	0.642
INN2: Our firm uses unique services by using technology.	0.716			
INN3: Our firm introduces a new way to complete logistic operations.	0.838			
NCA1: Our firm is enthusiastic about developing a relationship with clients.	0.856	0.749	0.857	0.666
NCA2: Our firm strongly connects with clients and solves problems constructively.	0.777			
NCA3: The strong network capability of our firm to improve logistics operations with the help of partners.	0.812			
RIS1: In logistics, both client and our firm take responsibility for any potential risk.	0.860	0.703	0.834	0.627
RIS2: Value co-creation enables our firm to take control of risk.	0.769			
RIS3: The co-creation process update clients and firm about any potential threat from logistic operations timely.	0.741			
SCR1: This firm has the capacity to adapt against supply chain disruption.	0.829	0.799	0.881	0.712
SCR2: This firm has ample resources to respond quickly to any crisis.	0.817			
SCR3: This firm is capable of recovering supply chain operations in a short time.	0.885			
TRN1: The proprietary information is shared between the firm and clients without hesitation.	0.866	0.790	0.877	0.705
TRN2: This firm share transparent information with its clients.	0.849			
TRN3: This firm adopts all new strategies that strengthen transparency.	0.802			
VCC1: This firm invites all stakeholders to design new logistic services.	0.836	0.785	0.875	0.700
VCC2: This firm encourages stakeholders to participate in the operational process of the supply chain.	0.784			
VCC3: This firm creates value co-creation by involving stakeholders in the new product development process.	0.888			

Note: CA: Cronbach Alpha (α); CR: Composite Reliability = $(\sum\lambda)^2 / (\sum\lambda)^2 + \Sigma e$; AVE: Average Variance Extracted = $\sum\lambda^2 / \sum\lambda^2 + \Sigma e$ and $e = 1 - \lambda^2; \chi^2/df$ – Chi-Square Test Statistic /Degrees of Freedom.

Sources: developed by the author.

The result of the measurement model has established adequate instrument reliability, construct reliability, and convergent validity of the measure. Nevertheless, the extent to wherein measures differentiate is confirmed with discriminant validity. In line with Fornell and Larcker (1981), discriminant validity is achieved with Fornell and Larcker criterion. This method indicates that the square root of AVE must be higher than other construct correlations (Fornell and Larcker, 1981). Results confirmed that the square root of AVE is higher when compared with other construct correlations, hence establishing discriminant validity of the constructs. Table 3 depicts the findings of the Fornell and Larcker analysis.

Table 3. Discriminant validity of the measure

	ACC	DIL	DIT	INN	NCA	RIS	SCR	TRN	VCC
ACC	0.792								
DIL	0.537	0.816							
DIT	0.733	0.556	0.836						
INN	0.616	0.585	0.536	0.802					
NCA	0.540	0.686	0.496	0.595	0.816				
RIS	0.640	0.692	0.626	0.613	0.569	0.792			
SCR	0.762	0.613	0.785	0.602	0.552	0.707	0.844		
TRN	0.711	0.584	0.823	0.562	0.509	0.766	0.857	0.839	
VCC	0.730	0.607	0.763	0.588	0.589	0.707	0.910	0.792	0.837

Note: ACC – Access; DIL – Dialogue; DIT – Digital Technology; INN – Innovation; NCA – Network Capability; RIS – Risk Assessment; SCR – Supply Chain Resilience; TRN – Transparency; VCC – Value Co-Creation.

Sources: developed by the authors.

The discriminant validity of the measure is further tested with cross loading method wherein the loading of the constructs is measured with corresponding measure loadings (Fornell and Larcker, 1981; Rahi et al., 2020a; Yamin and Sweiss, 2020). Findings of the cross-loading revealed that the indicator loading of the construct is higher when compared with corresponding constructs loadings. Therefore, establishing that construct is discriminant. Table 4 presents findings of the cross-loading analysis.

Table 4. Cross loadings

Items	ACC	DIL	DIT	INN	NCA	RIS	SCR	TRN	VCC
ACC1	0.842	0.454	0.645	0.547	0.436	0.571	0.692	0.656	0.665
ACC2	0.745	0.459	0.579	0.537	0.477	0.459	0.541	0.501	0.498
ACC3	0.798	0.362	0.527	0.421	0.411	0.477	0.572	0.539	0.544
ACC4	0.778	0.428	0.564	0.446	0.396	0.510	0.592	0.540	0.588
DIL1	0.472	0.796	0.481	0.500	0.600	0.515	0.501	0.450	0.482
DIL2	0.440	0.827	0.486	0.495	0.550	0.603	0.501	0.496	0.530
DIL3	0.402	0.825	0.389	0.436	0.531	0.573	0.501	0.483	0.471
DIT1	0.564	0.426	0.840	0.396	0.393	0.513	0.682	0.849	0.661
DIT2	0.549	0.469	0.841	0.455	0.345	0.511	0.625	0.682	0.574
DIT3	0.661	0.520	0.814	0.471	0.488	0.568	0.652	0.595	0.647
DIT4	0.668	0.446	0.850	0.471	0.425	0.500	0.661	0.622	0.660
INN1	0.477	0.509	0.466	0.844	0.517	0.538	0.518	0.517	0.483
INN2	0.449	0.465	0.342	0.716	0.441	0.390	0.419	0.332	0.422
INN3	0.551	0.437	0.470	0.838	0.472	0.535	0.505	0.488	0.504
NCA1	0.538	0.558	0.444	0.472	0.856	0.479	0.498	0.495	0.533
NCA2	0.347	0.527	0.329	0.515	0.777	0.440	0.407	0.329	0.416
NCA3	0.420	0.597	0.433	0.476	0.812	0.474	0.440	0.407	0.485
RIS1	0.582	0.553	0.545	0.479	0.441	0.860	0.642	0.802	0.649
RIS2	0.519	0.539	0.559	0.509	0.478	0.769	0.553	0.521	0.547
RIS3	0.398	0.565	0.363	0.478	0.441	0.741	0.467	0.446	0.461
SCR1	0.642	0.493	0.685	0.537	0.446	0.562	0.829	0.866	0.684
SCR2	0.635	0.491	0.668	0.466	0.403	0.553	0.817	0.615	0.709
SCR3	0.655	0.563	0.645	0.524	0.535	0.665	0.885	0.705	0.888
TRN1	0.642	0.493	0.685	0.537	0.446	0.562	0.829	0.866	0.684
TRN2	0.564	0.426	0.840	0.396	0.393	0.513	0.682	0.849	0.661
TRN3	0.582	0.553	0.545	0.479	0.441	0.860	0.642	0.802	0.649
VCC1	0.608	0.470	0.626	0.531	0.494	0.585	0.690	0.669	0.836
VCC2	0.567	0.486	0.648	0.417	0.445	0.515	0.693	0.612	0.784
VCC3	0.655	0.563	0.645	0.524	0.535	0.665	0.885	0.705	0.888

Note: ACC – Access; DIL – Dialogue; DIT – Digital Technology; INN – Innovation; NCA – Network Capability; RIS – Risk Assessment; SCR – Supply Chain Resilience; TRN – Transparency; VCC – Value Co-Creation.

Sources: calculated by the authors.

Although vertical collinearity has been established in the measurement model, lateral collinearity is tested with a variance inflation factor (Rahi, 2017; Yamin, 2020c). The VIF analyses postulate that variance inflation factor values must not exceed 3.3 (Rahi and Ghani, 2019; Yamin, 2020b; Yamin, 2020a). Results revealed that VIF values are less than threshold values ≤ 3.3 , confirming the lateral multi-collinearity of the constructs. Table 5 shows the results of the variance inflation factor analysis.

Table 5. Variance inflation factor analysis

Constructs	Supply Chain Resilience	Value Co-Creation
Access		2.698
Dialogue		2.144
Digital Technology		2.706
Innovation		1.967
Network Capability	1.716	
Risk Assessment		2.328
Transparency		2.616
Value Co-Creation	1.736	

Sources: developed by the authors.

The research model of this study comprises direct and moderating hypotheses and is tested with path coefficient, standard error, significance level, and t-statistics (Hair, 2003; Rahi and Ghani, 2019). Table 6 shows the results of the hypotheses.

Table 6. Hypotheses testing

Hypothesis	Relationship	Path Coefficient	STDEV	T-Statistics	Significance	Decision
H1	DIL -> VCC	0.091	0.046	1.996	0.037	Accepted
H2	ACC -> VCC	0.203	0.055	3.713	0.002	Accepted
H3	RIS -> VCC	0.119	0.051	2.328	0.021	Accepted
H4	TRN -> VCC	0.293	0.052	5.644	0.000	Accepted
H5	INN -> VCC	0.055	0.061	0.907	0.193	Not - Accepted
H6	DIT -> VCC	0.218	0.053	4.097	0.001	Accepted
H7	VCC -> SCR	0.880	0.023	38.162	0.000	Accepted

Note: ACC – Access; DIL – Dialogue; DIT – Digital Technology; INN – Innovation; NCA – Network Capability; RIS – Risk Assessment; SCR – Supply Chain Resilience; TRN – Transparency; VCC – Value Co-Creation.

Sources: developed by the authors.

The result of the structural model demonstrates that dialogue positively impacts creating value co-creation between manufacturing firms and stakeholders. It is statistically supported by H1: $\beta= 0.091$ path coefficient, significance $p < 0.037$, and t-statistics 1.996. Likewise, access has revealed a positive impact in developing value co-creation between firms and stakeholders. H2 supports it: $\beta= 0.203$ path coefficient, significance $p < 0.002$, and t-statistics 3.713. The impact of risk assessment towards value co-creation was found significant and supported by H3: $\beta= 0.119$ path coefficient, significance $p < 0.021$, and t-statistics 2.328. Alike, transparency in the supply chain process has shown a positive impact in creating value co-creation and is supported by H4: $\beta= 0.293$ path coefficient, significance $p < 0.000$, and t-statistics 5.644. Nevertheless, the relationship between innovation and value co-creation was found insignificant $\beta= 0.055$ path coefficient, significance $p < 0.907$, and t-statistics .907. Therefore, H5 has been rejected. Digital technology has shown a positive impact in creating value co-creation and is supported by H6: $\beta= 0.218$ path coefficient, significance $p < 0.01$, and t-statistics 4.097. Next to this, the value co-creation has established a positive impact on supply chain resilience and is supported by H7: $\beta= 0.880$ path coefficient, significance $p < 0.001$, and t-statistics 38.162.

The effect size analysis f^2 revealed the small effect of all independent variables in measuring value co-creation. Nonetheless, innovation has shown no effect on value co-creation. In measuring supply chain resilience, value co-creation shows a substantial effect size. The predictive power is measured with the blindfolding procedure Q^2 . Results of the blindfolding procedure revealed substantial predictive power 0.551 % in predicting value co-creation.

Similarly, the research model revealed substantial predictive power of 0.551 % in predicting supply chain resilience with value co-creation and network capability. Like substantial predictive power, the research model has shown sizable variance in measuring value co-creation R^2 0.719 % and supply chain resilience R^2 .830 % and hence confirmed the statistical validity of the research model. Table 7 depicts the values of predictive power analysis, coefficient of determination, and effect size analysis.

Table 7. Coefficient of determination, effect size, and blindfolding analysis Q^2

Value Co-Creation				
Constructs	R^2	Q^2	f^2	Findings
Value Co-Creation	0.719 %	0.551 %		
Access			0.055	Small effect
Dialogue			0.014	Small effect
Digital Technology			0.045	Small effect
Innovation			0.000	No-effect
Risk Assessment			0.015	Small effect
Transparency			0.066	Small effect
Supply Chain Resilience				
Constructs	R^2	Q^2	f^2	Findings
Supply Chain Resilience	0.830 %	0.473 %		
Network Capability			0.013	Small effect size
Value Co-Creation			2.631	Large effect size

Note: R Square: the variance in the endogenous variable explained by the exogenous variable(s). Q-square is predictive relevance, measures whether a model has predictive relevance or not (> 0 is good). f-square is effect size (>=0.02 is small; >= 0.15 is medium; >= 0.35 is large).

Sources: developed by the authors.

Importance of performance matrix analysis. The importance and performance of the variables are calculated through the importance-performance matrix method (IPMA) consistent with prior studies (Hair et al., 2011; Rahi, 2017; Rahi et al., 2020b). According to Rahi et al. (2019), the IPMA method rescales data from 0 to 10 and then estimates the values. The current research framework has two endogenous variables: value co-creation and supply chain resilience. Therefore, in IPMA, supply chain resilience is considered an outcome variable. Findings revealed that value co-creation is the most important variable due to high-importance values. Therefore, transparency, access, and digital technology are important at the second level. Interestingly, dialogue, innovation, and network capability have shown less importance in measuring supply chain resilience. Table 8 exhibits the results of the important performance matrix analysis.

Table 8. Findings of importance-performance analysis

Constructs	SCR Importance	Performances of SCR
Access	0.202	77.999
Dialogue	0.094	74.981
Digital Technology	0.182	77.333
Innovation	0.058	8.714
Network Capability	0.009	76.232
Risk Assessment	0.114	76.279
Transparency	0.244	8.463
Value Co-Creation	0.922	78.738

Note: SCR – Supply Chain Resilience.

Sources: developed by the authors.

The importance of the factors is outlined in the IPMA map. Results indicate that network capability has the lowest importance in measuring supply chain resilience. However, innovation has the second lowest importance towards supply chain resilience. The results of the IPMA exhibit that factors such as transparency, access, digital technology, and value co-creation are important factors that need policymakers' attention to enhance supply chain resilience in manufacturing firms. Figure 2 presents IPMA map.

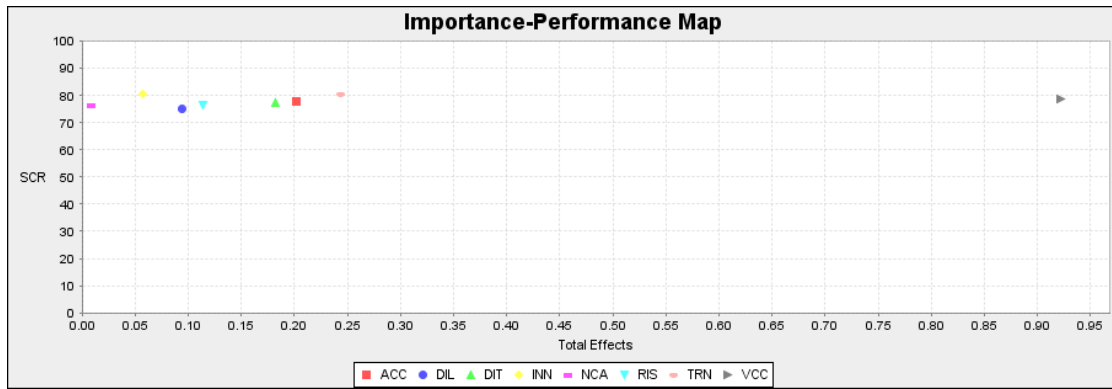

Figure 2. IPMA map for construct importance & performance

The network capability increases commitment and bonding between firm and supply chain partners and enhances value co-creation (Schreiner et al., 2009). Therefore, examining the impact of network capability as moderating variable between value co-creation and supply chain resilience is essential. The moderating effect of network capability is tested with the product indicator approach in line with prior studies (Rahi, 2015; Sweiss and Yamin, 2020). The finding of the moderating effect has confirmed a significant moderating impact of network capability between value co-creation and supply chain resilience and is supported by $\beta= 0.126$, significant at $p < 0.05$, t-statistics 1.914). Hence, H8 is confirmed. Figure 3 demonstrates the result of the moderating relationship of network capability with t-statistics.

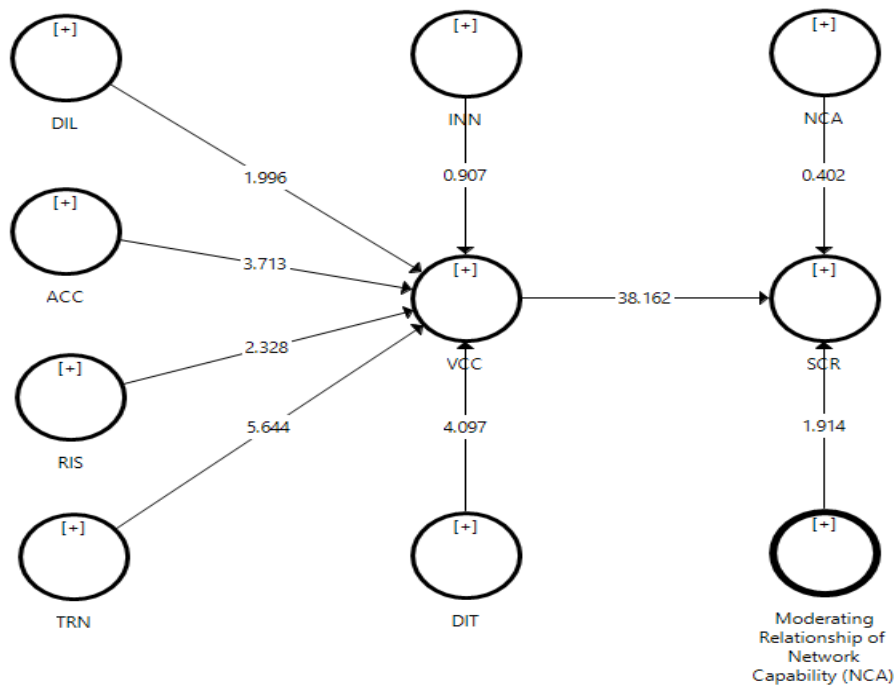

Figure 3. The moderating effect of network capability

Sources: developed by the authors.

Results. The rising uncertainty in businesses requires firms to develop resilient strategies to survive in the competitive market. Therefore, in this study supply chain resilience is determined by value co-creation, the DART model, innovation, and digital technology. The factors underpinning the DART model, including dialogue, access, risk assessment, and transparency, have positively impacted value co-creation. The structural model shows that dialogue has a positive impact on developing value co-creation between manufacturing firms and stakeholders, consistent with previous studies conducted by Prahalad and Ramaswamy (2004). Similarly, access has shown a positive impact on creating value co-creation between firms and stakeholders, in line with Fernando and Chukai (2018). Risk assessment has shown a positive impact on value co-creation. It is in line with Yazdanparast et al. (2010). Similarly, transparency in the supply chain has shown a positive impact on measuring value co-creation. It is consistent with Ramaswamy and Ozcan (2018), Saarijärvi et al.

(2013), Yazdanparast et al. (2010). The results of the structural model revealed that innovation does not influence value co-creation and therefore negates arguments previously developed by a previous study (Agarwal and Selen, 2019). Innovation brings newness and major changes in supply chain operations that enhance customer satisfaction and product performance. However, this research revealed that major changes in operations and newness could not influence value co-creation. A possible reason could be that stakeholders feel uncomfortable with changes in operations and newness, and hence innovation is not favorable in creating value co-creation among supply chain stakeholders. Concerning digital technology, results revealed a significant impact of digital technology on value co-creation. It is consistent with Ju et al. (2021). Value co-creation has positively impacted supply chain resilience and is consistent with a prior study by Ju et al. (2021).

The moderating effect of network capability is tested between value co-creation and supply chain resilience to establish a strong relationship with supply chain partners. Findings revealed that the extension of network capability among stakeholder supply chain managers could enhance value co-creation and supply chain resilience in logistic operations. The validity of the research model has been confirmed through the coefficient of determination and predictive relevance of the research model. The value co-creation is estimated with the DART model, innovation, and digital technology and explains substantial variance R^2 71.9% in value co-creation. Moving further, network capability and value co-creation revealed substantial variance R^2 83.0% in supply chain resilience and hence confirmed the acceptability of the supply chain resilient model. Blindfolding analysis has shown that factors underpinning the research model have substantial power to predict value co-creation among supply chain stakeholders and supply chain resilience during COVID-19. Finally, the research model is evaluated with IPMA analysis to understand the broader impact of outlined factors on supply chain resilience. Results of the IPMA analysis indicate that value co-creation, transparency in supply chain operations, access to product development, and digital technology are the influential factors that could help firms to become resilient in supply chain operations.

This research contributes to theory largely as it integrates multiple supply chain factors to investigate value co-creation and supply chain resilience. In this study, literature has synthesized that factor such as dialogue, access, risk assessment, transparency, value co-creation, and digital technology are the most influential factor in determining supply chain resilience. Another theoretical aspect of this research is to confirm the moderating effect of network capability between value co-creation and supply chain resilience. Empirical findings have confirmed the moderating effect of network capability between value co-creation and supply chain resilience. Practically, this research reveals useful findings that will help manufacturers to understand how to develop value co-creation and resilience strategies in supply chain process. This study suggests that factors such as dialogue, access, risk assessment, transparency, and digital technology significantly impact value co-creation. Therefore, managers and policymakers should consider these factors in developing new supply chain strategies. Second, this research directs that value co-creation is the core antecedent of supply chain resilience. These findings indicate that logistics managers can handle disruption in a supply chain by creating value co-creation between the firm and supply chain stakeholders. Similarly, managers must develop strong network capability among stakeholders, positively influencing value co-creation and supply chain resilience. To sum up, this study suggests that factors underpinning the DART model with digital technology and network capability provide a holistic view to improve value co-creation and resilience in supply chain operations during the COVID-19 pandemic.

Conclusions. COVID-19 has affected business operations worldwide. Therefore, understanding factors influencing supply chain resilience is important for sustainable operations. The current study introduces an integrated resilient supply chain model that combines factors such as dialogue, access, risk assessment, transparency, innovation, and digital technology to investigate value co-creation and supply chain resilience. The value co-creation is determined by dialogue, access, risk assessment, transparency, innovation, and digital technology and revealed substantial variance R^2 71.9% in measuring value co-creation. In line with the research objective, this research has confirmed that value co-creation is an important antecedent of supply chain resilience and revealed a large variance R^2 83.0% in measuring supply chain resilience. The validity of the research model was established with the blindfolding procedure. Results of the blindfolding procedure revealed substantial predictive power 55.1% in predicting value co-creation.

Similarly, the research model revealed substantial predictive power 55.1% in predicting supply chain resilience with value co-creation and network capability. Contrary to researcher expectations, innovation has shown an insignificant impact on value co-creation. It indicates that innovation brings newness and major changes in supply chain operations that enhance customer satisfaction and product performance. However, these changes or disruptions may not be acceptable for supply chain stakeholders and negatively impact value

co-creation. The effect size analysis f^2 revealed the small effect of all independent variables in measuring value co-creation. Nevertheless, in measuring supply chain resilience, value co-creation has shown a substantial effect size. Moreover, network capability is outlined as moderating variable between value co-creation and supply chain resilience. This study has confirmed that extending the role of network capability among supply chain stakeholders will enhance the relationship between value co-creation and supply chain resilience. In terms of contributions, this research has synthesized that factor such as dialogue, access, risk assessment, transparency, value co-creation, and digital technology are the most influential factor in predicting supply chain resilience. Practically, this research recommends that logistics managers can handle disruption in a supply chain by creating value co-creation between firm and supply chain stakeholders. Additionally, it is confirmed that strong network capability among stakeholders will positively influence value co-creation and supply chain resilience. The results of the IPMA exhibit that factors such as transparency, access, digital technology, and value co-creation are the core factors that need policymakers' attention to enhance supply chain resilience in manufacturing firms during the COVID-19 pandemic.

Although current research contributes to theory, practice, and method, disclosing research limitations opens numerous avenues for future researchers. Primarily, the value co-creation is estimated by factors underpinned DART model, innovation, and digital technology. Nevertheless, this study does not claim to include all factors that impact the value co-creation process in supply chain operations. For instance, other factors, such as IT infrastructure, commitment, and integrative quality, may positively influence value co-creation. Second, supply chain resilience is determined by value co-creation and network capability. Therefore, the research encourages academicians and policymakers to investigate the supply chain resilience phenomenon with other market-oriented facts. This cross-sectional study empirically tests the causal relationship between exogenous and endogenous variables. However, future researchers are suggested to investigate the current research model in longitudinal method. This study investigates the moderating effect of network capability between value co-creation and supply chain resilience. However, the mediating role of value co-creation is yet to be examined. Therefore, future researchers are encouraged to test the mediating role of value co-creation between the DART model and supply chain resilience. Another limitation of this study is the sampling approach. Data have been collected using a convenience sampling approach because the list of employees working in manufacturing companies was not available. Finally, it is recommended that the current resilient integrated supply chain model should be tested in other emerging economies except Saudi Arabia to see how values vary from country to country in supply chain operations.

Author Contributions: conceptualization, M. A.; methodology, M. A. and O. A.; software, M. A. and O. A.; validation, M. A.; formal analysis, M. A. and O. A.; investigation, M. A.; resources, M. A.; data curation, M. A.; writing-original draft preparation, M. A.; writing-review and editing, M. A. and O. A.; visualization, M. A.; supervision, M. A.; project administration, O. A.; funding acquisition, O. A.

Conflicts of Interest: Authors declare no conflict of interest.

Data Availability Statement: Not applicable.

Informed Consent Statement: Not applicable.

References

- Aamer, A. M., Al-Awlaqi, M. A., Affia, I., Arumsari, S., & Mandahawi, N. (2021). The internet of things in the food supply chain: adoption challenges. *Benchmarking: An International Journal*, 28(8), 2521-2541. [\[Google Scholar\]](#) [\[CrossRef\]](#)
- Afraz, M. F., Bhatti, S. H., Ferraris, A., & Couturier, J. (2021). The impact of supply chain innovation on competitive advantage in the construction industry: Evidence from a moderated multi-mediation model. *Technological Forecasting and Social Change*, 162, 120370. [\[Google Scholar\]](#) [\[CrossRef\]](#)
- Agarwal, R., & Selen, W. (2009). Dynamic capability building in service value networks for achieving service innovation. *Decision sciences*, 40(3), 431-475. [\[Google Scholar\]](#) [\[CrossRef\]](#)
- Andriopoulos, C., & Lewis, M. W. (2009). Exploitation-exploration tensions and organizational ambidexterity: Managing paradoxes of innovation. *Organization science*, 20(4), 696-717. [\[Google Scholar\]](#) [\[CrossRef\]](#)
- Bader, A. A., & Mohammad, A. Y. Y. (2019). The impact of task technology fit on employee job performance. *Marketing and Management of Innovations*, 4, 140-159. [\[Google Scholar\]](#) [\[CrossRef\]](#)

- Bhamra, R., Dani, S., & Burnard, K. (2011). Resilience: the concept, a literature review and future directions. *International journal of production research*, 49(18), 5375-5393. [\[Google Scholar\]](#) [\[CrossRef\]](#)
- Blackhurst, J., Dunn, K. S., & Craighead, C. W. (2011). An Empirically Derived Framework of Global Supply Resiliency. *Journal of business logistics*, 32(4), 374-391. [\[Google Scholar\]](#) [\[CrossRef\]](#)
- Bode, C., Wagner, S. M., Petersen, K. J., & Ellram, L. M. (2011). Understanding responses to supply chain disruptions: Insights from information processing and resource dependence perspectives. *Academy of Management Journal*, 54(4), 833-856. [\[Google Scholar\]](#) [\[CrossRef\]](#)
- Brandon-Jones, E., Squire, B., Autry, C. W., & Petersen, K. J. (2014). A contingent resource-based perspective of supply chain resilience and robustness. *Journal of Supply Chain Management*, 50(3), 55-73. [\[Google Scholar\]](#) [\[CrossRef\]](#)
- Cichosz, M., Wallenburg, C. M., & Knemeyer, A. M. (2020). Digital transformation at logistics service providers: barriers, success factors and leading practices. *The International Journal of Logistics Management*, 31(2), 209-238. [\[Google Scholar\]](#) [\[CrossRef\]](#)
- de Sousa Jabbour, A. B. L., Jabbour, C. J. C., Hingley, M., Vilalta-Perdomo, E. L., Ramsden, G., & Twigg, D. (2020). Sustainability of supply chains in the wake of the coronavirus (COVID-19/SARS-CoV-2) pandemic: lessons and trends. *Modern Supply Chain Research and Applications*. [\[Google Scholar\]](#) [\[CrossRef\]](#)
- Fernando, Y., & Chukai, C. (2018). Value co-creation, goods and service tax (GST) impacts on sustainable logistic performance. *Research in Transportation Business & Management*, 28, 92-102. [\[Google Scholar\]](#) [\[CrossRef\]](#)
- Fornell, C., & Larcker, D. F. (1981). Structural Equation Models with Unobservable Variables and Measurement Error: Algebra and Statistics. *Journal of Marketing Research*, 18(23), 382-388. [\[Google Scholar\]](#) [\[CrossRef\]](#)
- Grandy, G., & Levit, T. (2015). Value co-creation and stakeholder complexity: what strategy can learn from churches. *Qualitative Research in Organizations and Management*, 10(3), 243. [\[Google Scholar\]](#) [\[CrossRef\]](#)
- Green, K. W., Whitten, D., & Inman, R. A. (2008). The impact of logistics performance on organizational performance in a supply chain context. *Supply Chain Management: An International Journal*, 13(4), 317-327. [\[Google Scholar\]](#) [\[CrossRef\]](#)
- Hair Jr, J. F., Babin, B., Money, A. H., & Samouel, P. (2003). Essentials of business research methods: Johns Wiley & Sons. Inc., United States of America. [\[Google Scholar\]](#)
- Hair Jr, J. F., Sarstedt, M., Hopkins, L., & Kuppelwieser, V. G. (2014). Partial least squares structural equation modeling (PLS-SEM): An emerging tool in business research. *European business review*. [\[Google Scholar\]](#) [\[CrossRef\]](#)
- Hair, J. F., Ringle, C. M., & Sarstedt, M. (2011). PLS-SEM: Indeed a silver bullet. *Journal of Marketing theory and Practice*, 19(2), 139-152. [\[Google Scholar\]](#) [\[CrossRef\]](#)
- Hopkins, J. L. (2021). An investigation into emerging industry 4.0 technologies as drivers of supply chain innovation in Australia. *Computers in Industry*, 125, 103323. [\[Google Scholar\]](#) [\[CrossRef\]](#)
- Ivanov, D., Dolgui, A., & Sokolov, B. (2019). The impact of digital technology and Industry 4.0 on the ripple effect and supply chain risk analytics. *International Journal of Production Research*, 57(3), 829-846. [\[Google Scholar\]](#) [\[CrossRef\]](#)
- Ju, Y., Hou, H., & Yang, J. (2020). Integration quality, value co-creation and resilience in logistics service supply chains: moderating role of digital technology. *Industrial Management & Data Systems*, 121(2), 364-380. [\[Google Scholar\]](#) [\[CrossRef\]](#)
- Karmaker, C. L., Ahmed, T., Ahmed, S., Ali, S. M., Moktadir, M. A., & Kabir, G. (2021). Improving supply chain sustainability in the context of COVID-19 pandemic in an emerging economy: Exploring drivers using an integrated model. *Sustainable production and consumption*, 26, 411-427. [\[Google Scholar\]](#) [\[CrossRef\]](#)
- Kauppila, O. P. (2015). Alliance management capability and firm performance: Using resource-based theory to look inside the process black box. *Long Range Planning*, 48(3), 151-167. [\[Google Scholar\]](#) [\[CrossRef\]](#)
- Liu, W., Wang, S., Lin, Y., Xie, D., & Zhang, J. (2020). Effect of intelligent logistics policy on shareholder value: Evidence from Chinese logistics companies. *Transportation Research Part E: Logistics and Transportation Review*, 137, 101928. [\[Google Scholar\]](#) [\[CrossRef\]](#)
- Masa'deh, R. E., Al-Henzab, J., Tarhini, A., & Obeidat, B. Y. (2018). The associations among market orientation, technology orientation, entrepreneurial orientation and organizational performance. *Benchmarking: An International Journal*, 25(8), 3117-3142. [\[Google Scholar\]](#) [\[CrossRef\]](#)

Mitrega, M., Forkmann, S., Ramos, C., & Henneberg, S. C. (2012). Networking capability in business relationships—Concept and scale development. *Industrial Marketing Management*, 41(5), 739-751. [\[Google Scholar\]](#) [\[CrossRef\]](#)

Partanen, J., Kohtamäki, M., Patel, P. C., & Parida, V. (2020). Supply chain ambidexterity and manufacturing SME performance: The moderating roles of network capability and strategic information flow. *International Journal of Production Economics*, 221, 107470. [\[Google Scholar\]](#) [\[CrossRef\]](#)

Partouche-Sebban, J., Vessal, S. R., & Bernhard, F. (2021). When co-creation pays off: the effect of co-creation on well-being, work performance and team resilience. *Journal of Business & Industrial Marketing*. [\[Google Scholar\]](#) [\[CrossRef\]](#)

Paulraj, A., Lado, A. A., & Chen, I. J. (2008). Inter-organizational communication as a relational competency: Antecedents and performance outcomes in collaborative buyer–supplier relationships. *Journal of operations management*, 26(1), 45-64. [\[Google Scholar\]](#) [\[CrossRef\]](#)

Pillai, R., & Sivathanu, B. (2020). Adoption of internet of things (IoT) in the agriculture industry deploying the BRT framework. *Benchmarking: An International Journal*, 27(4), 1341-1368. [\[Google Scholar\]](#) [\[CrossRef\]](#)

Podsakoff, P. M., MacKenzie, S. B., Lee, J. Y., & Podsakoff, N. P. (2003). Common method biases in behavioral research: a critical review of the literature and recommended remedies. *Journal of applied psychology*, 88(5), 879. [\[Google Scholar\]](#)

Prahalad, C. K., & Ramaswamy, V. (2004). Co-creation experiences: The next practice in value creation. *Journal of interactive marketing*, 18(3), 5-14. [\[Google Scholar\]](#) [\[CrossRef\]](#)

Rahi, S. (2015). Moderating role of brand image with relation to internet banking and customer loyalty: a case of branchless banking. *The Journal of Internet Banking and Commerce*, 20(3): 131 [\[Google Scholar\]](#) [\[CrossRef\]](#)

Rahi, S. (2017). Research design and methods: A systematic review of research paradigms, sampling issues and instruments development. *International Journal of Economics & Management Sciences*, 6(2), 1-5. [\[Google Scholar\]](#) [\[CrossRef\]](#)

Rahi, S., & Ghani, M. A. (2018). Does gamified elements influence on user's intention to adopt and intention to recommend internet banking?. *The International Journal of Information and Learning Technology*. [\[Google Scholar\]](#) [\[CrossRef\]](#)

Rahi, S., & Ghani, M. A. (2018). The role of UTAUT, DOI, perceived technology security and game elements in internet banking adoption. *World Journal of Science, Technology and Sustainable Development*. 15(4), 338-356. [\[Google Scholar\]](#) [\[CrossRef\]](#)

Rahi, S., Ghani, M. A., & Ngah, A. H. (2020a). Factors propelling the adoption of internet banking: the role of e-customer service, website design, brand image and customer satisfaction. *International Journal of Business Information Systems*, 33(4), 549-569. [\[Google Scholar\]](#) [\[CrossRef\]](#)

Rahi, S., Ghani, M., & Ngah, A. (2018). A structural equation model for evaluating user's intention to adopt internet banking and intention to recommend technology. *Accounting*, 4(4), 139-152. [\[Google Scholar\]](#) [\[CrossRef\]](#)

Rahi, S., Khan, M. M., & Alghizzawi, M. (2020b). Extension of technology continuance theory (TCT) with task technology fit (TTF) in the context of Internet banking user continuance intention. *International Journal of Quality & Reliability Management*, 38(4), 986-1004. [\[Google Scholar\]](#) [\[CrossRef\]](#)

Rahi, S., Mansour, M. M. O., Alghizzawi, M., & Alnaser, F. M. (2019). Integration of UTAUT model in internet banking adoption context: The mediating role of performance expectancy and effort expectancy. *Journal of Research in Interactive Marketing*. 13(3), 411-435. [\[Google Scholar\]](#) [\[CrossRef\]](#)

Rahi, S., Mansour, M. M. O., Alharafsheh, M., & Alghizzawi, M. (2021). The post-adoption behavior of internet banking users through the eyes of self-determination theory and expectation confirmation model. *Journal of Enterprise Information Management*. 34(6), 1874-1892 [\[Google Scholar\]](#) [\[CrossRef\]](#)

Ramaswamy, V., & Ozcan, K. (2018). What is co-creation? An interactional creation framework and its implications for value creation. *Journal of business research*, 84, 196-205. [\[Google Scholar\]](#) [\[CrossRef\]](#)

Ren, S. J., Hu, C., Ngai, E. W. T., & Zhou, M. (2015). An empirical analysis of inter-organisational value co-creation in a supply chain: a process perspective. *Production Planning & Control*, 26(12), 969-980. [\[Google Scholar\]](#) [\[CrossRef\]](#)

Rowley, J. (2014). Designing and using research questionnaires. *Management Research Review*, 37(3), 308. [\[Google Scholar\]](#) [\[CrossRef\]](#)

- Saarijärvi, H., Karjaluoto, H., & Kuusela, H. (2013). Extending customer relationship management: from empowering firms to empowering customers. *Journal of Systems and Information Technology*, 15(2), 140-158. [\[Google Scholar\]](#) [\[CrossRef\]](#)
- Schreiner, M., Kale, P., & Corsten, D. (2009). What really is alliance management capability and how does it impact alliance outcomes and success?. *Strategic management journal*, 30(13), 1395-1419. [\[Google Scholar\]](#) [\[CrossRef\]](#)
- Semrau, T., & Sigmund, S. (2012). Networking ability and the financial performance of new ventures: A mediation analysis among younger and more mature firms. *Strategic Entrepreneurship Journal*, 6(4), 335-354. [\[Google Scholar\]](#) [\[CrossRef\]](#)
- Singh, A. (2022). Work engagement, affective commitment, and career satisfaction: the mediating role of knowledge sharing in context of SIEs. *Benchmarking: An International Journal*. [\[Google Scholar\]](#) [\[CrossRef\]](#)
- Singh, N. P., & Singh, S. (2019). Building supply chain risk resilience: Role of big data analytics in supply chain disruption mitigation. *Benchmarking: An International Journal*, 26(7), 2318-2342. [\[Google Scholar\]](#) [\[CrossRef\]](#)
- Sinkovics, R. R., Kuivalainen, O., & Roath, A. S. (2018). Value co-creation in an outsourcing arrangement between manufacturers and third party logistics providers: resource commitment, innovation and collaboration. *Journal of Business & Industrial Marketing*. 33(4), 563-573. [\[Google Scholar\]](#) [\[CrossRef\]](#)
- Sweiss, M. I. K., & Yamin, M. A. Y. (2020). The influence of organisational and individual factors on organisational innovation with moderating role of innovation orientation. *International Journal of Business Innovation and Research*, 23(1), 103-126. [\[Google Scholar\]](#) [\[CrossRef\]](#)
- Tian, H., Otchere, S. K., Coffie, C. P., Mensah, I. A., & Baku, R. K. (2021). Supply chain integration, interfirm value co-creation and firm performance nexus in Ghanaian SMEs: mediating roles of stakeholder pressure and innovation capability. *Sustainability*, 13(4), 2351. [\[Google Scholar\]](#) [\[CrossRef\]](#)
- Utami, H. N., Alamanos, E., & Kuznesof, S. (2021). 'A social justice logic': how digital commerce enables value co-creation at the bottom of the pyramid. *Journal of Marketing Management*, 37(9-10), 816-855. [\[Google Scholar\]](#) [\[CrossRef\]](#)
- Yamin, M. (2020a). Examining the role of transformational leadership and entrepreneurial orientation on employee retention with moderating role of competitive advantage. *Management Science Letters*, 10(2), 313-326. [\[Google Scholar\]](#) [\[CrossRef\]](#)
- Yamin, M. A. Y. (2019). The mediating role of ethical organisational climate between HRM practices and HR outcomes in public sector of Saudi Arabia. *International Journal of Business Excellence*, 19(4), 557-573. [\[Google Scholar\]](#) [\[CrossRef\]](#)
- Yamin, M. A. Y. (2020b). Examining the effect of organisational innovation on employee creativity and firm performance: Moderating role of knowledge sharing between employee creativity and employee performance. *International Journal of Business Innovation and Research*, 22(3), 447-467. [\[Google Scholar\]](#) [\[CrossRef\]](#)
- Yamin, M. A. Y. (2020c). The relationship between RIGHT ethical behavior perspective, demographic factors, and BEST ethical performance. *International Review of Management and Marketing*, 10(1), 27. [\[Google Scholar\]](#) [\[CrossRef\]](#)
- Yamin, M. A. Y., & Alyoubi, B. A. (2020). Adoption of telemedicine applications among Saudi citizens during COVID-19 pandemic: An alternative health delivery system. *Journal of infection and public health*, 13(12), 1845-1855. [\[Google Scholar\]](#) [\[CrossRef\]](#)
- Yamin, M. A. Y., & Mahasneh, M. S. (2018). The impact of values-based leadership on ethical loyalty in Saudi Arabian health organizations. *International Review of Management and Marketing*, 8(3), 6. [\[Google Scholar\]](#)
- Yamin, M. A. Y., & Sweiss, M. I. K. (2020). Investigating Employee creative performance with integration of DeLone and McLean Information system success model and Technology acceptance model: The moderating role of Creative self-efficacy. *International Journal of Business Excellence*, 22(3), 396-417. [\[Google Scholar\]](#) [\[CrossRef\]](#)
- Yazdanparast, A., Manuj, I., & Swartz, S. M. (2010). Co-creating logistics value: a service-dominant logic perspective. *International Journal of Logistics Management*, 21(3), 375-403. [\[Google Scholar\]](#) [\[CrossRef\]](#)

Оміма Абдалатіф, Ph.D., Університет Джидди, Саудівська Аравія
Мохаммад Ямін, Ph.D., доцент, Університет Джидди, Саудівська Аравія

Управління глобальними ланцюгами поставок підприємств на основі моделі DART: взаємозв'язок інновацій та цифрових технологій

Ця стаття узагальнює аргументи та контраргументи в межах наукової дискусії з питання управління глобальними ланцюгами постачань. Систематизація літературних джерел та підходів до розв'язання проблеми управління глобальними ланцюгами постачань засвідчила, що з урахуванням нових викликів і загроз потребують трансформації процеси управління як самими підприємствами, так і їх ланцюгами постачань. Актуальність розв'язання наукової проблеми полягає в тому, що пандемія COVID-19 мала значний вплив на виробничі процеси майже усіх галузей економіки всього світу, що призвело до загрози функціонування глобальних ланцюгів постачання. Компанії змушені шукати чинники, які впливають на стійкість ланцюга постачання та покращують операційну ефективність діяльності. Метою даної роботи є дослідження стійкості ланцюга постачання компанії під час дії пандемії COVID-19. Для досягнення поставленої мети, у рамках даного дослідження авторами розроблено інтегровану стійку модель ланцюга постачання. Представлена модель поєднує фактори, які лежать в основі моделі DART: інновації, цифрові технології та створена спільна додана вартість. Детерміновану вибірку даних сформовано на основі результатів опитування 329 співробітників логістичних компаній. За результатами емпіричного дослідження встановлено, що створення спільної доданої вартості в ланцюгу постачання оцінюється наступними факторами: діалог, доступ, оцінка ризиків, прозорість, інновації та цифрові технології. Окрім цього, результати емпіричного аналізу засвідчили, що рівень пояснювальної дисперсії для обраної моделі у створенні спільної доданої вартості становив 71.9%. Результати дослідження мають практичне значення та можуть бути взяті до уваги при розробці стійкої моделі ланцюга постачання із поєднанням моделі DART: інновацій, цифрових технологій та створення спільної доданої вартості.

Ключові слова: COVID-19, діалог, мережеві можливості, стійкість, оцінка ризику, прозорість.